



WORLD  CLASS  
**CARGO**  
SECUREMENT  
KEEPING PEOPLE **SAFE**  
FOR **50** YEARS

CATALOGUE  
2021

**WISTRA**  
CARGO CONTROL  
THE HEICO COMPANIES

---

## Deployed all over Europe



### Version January 2021

Subject to technical changes and copyright. Deliveries are exclusively subject to our conditions of sale and delivery. This catalogue is our intellectual property! Re-printing and reproduction - including excerpts - as well as the use of our images, is only permitted with our prior written permission. We assume no warranty for the data, descriptions, representations, notes and recommendations for use of the products available from our company and detailed in this catalogue. In principle, legal claims cannot be made based on this because deployment and use are generally beyond our control. Moreover, users are obliged to check and decide for themselves whether the items offered by our company can be used in individual cases.

WISTRA GmbH

# Table of Contents

<b>General</b>	<b>4</b>
<b>Cargo securing for tarpaulin and platform vehicles</b>	<b>12</b>
Lashing straps	13
Edge protection and non-slip mats	21
Longitudinal bars	26
Parting wall locks	27
Double-deck system for curtainsiders	29
FIX products	32
Daken products	36
<b>Cargo securing for box trucks</b>	<b>42</b>
Lashing tracks	43
Lashing straps	50
Shoring beams	52
Cargo bars	59
Decking beams	60
Garment rails	63
Door gears	64
<b>Cargo securing for transporters and trailers</b>	<b>66</b>
Airline lashing rails	67
Lashing points	82
Fittings / end fittings and accessories	83
AirlineStop	89
Lashing straps	90
Cargo securing nets	96
Shoring beams	109
Parting wall locks	116
Garment rails	116
Cargo securing wall for transporters	117
<b>Cargo securing for car transporters and trailers</b>	<b>118</b>
Car transport lashings straps	119
<b>Other</b>	<b>122</b>
Lifting technology	123
Security seals and anti-theft devices	127
One-way lashing	128
<b>Interesting facts</b>	<b>130</b>

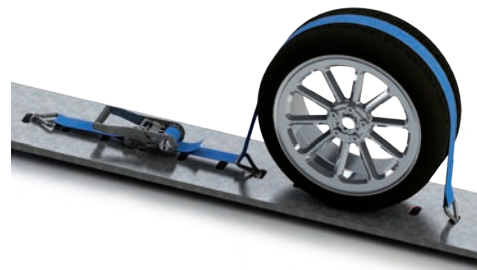

---

## Our experience guarantees your safety!

Dear customer,

We are pleased to welcome you with our current catalogue.

On the following pages you will be able to acquaint yourself with WISTRA GmbH.

The individual categories will provide you with an overall impression of the capability of our modern company and of our products and services.

Besides our well-known products, we present the latest product developments and accessories of our product range.

We look forward to working with you and wish you pleasant browsing in our catalogue.

Yours



Mark Zubel



---

### The company

WISTRA offers a wide product range of textile and mechanical aids for cargo securing.

Our market position is based on competent staff who fulfil your needs with expertise and experience as well as application-oriented and high-quality products at market-related prices.

**WISTRA – your first contact for innovative cargo securing systems in Europe**

In addition, we are a member of the Heico Group with American market leaders in the field of cargo securing in development and production.

## More than 30 years of quality, continuous further development and technical modernisation

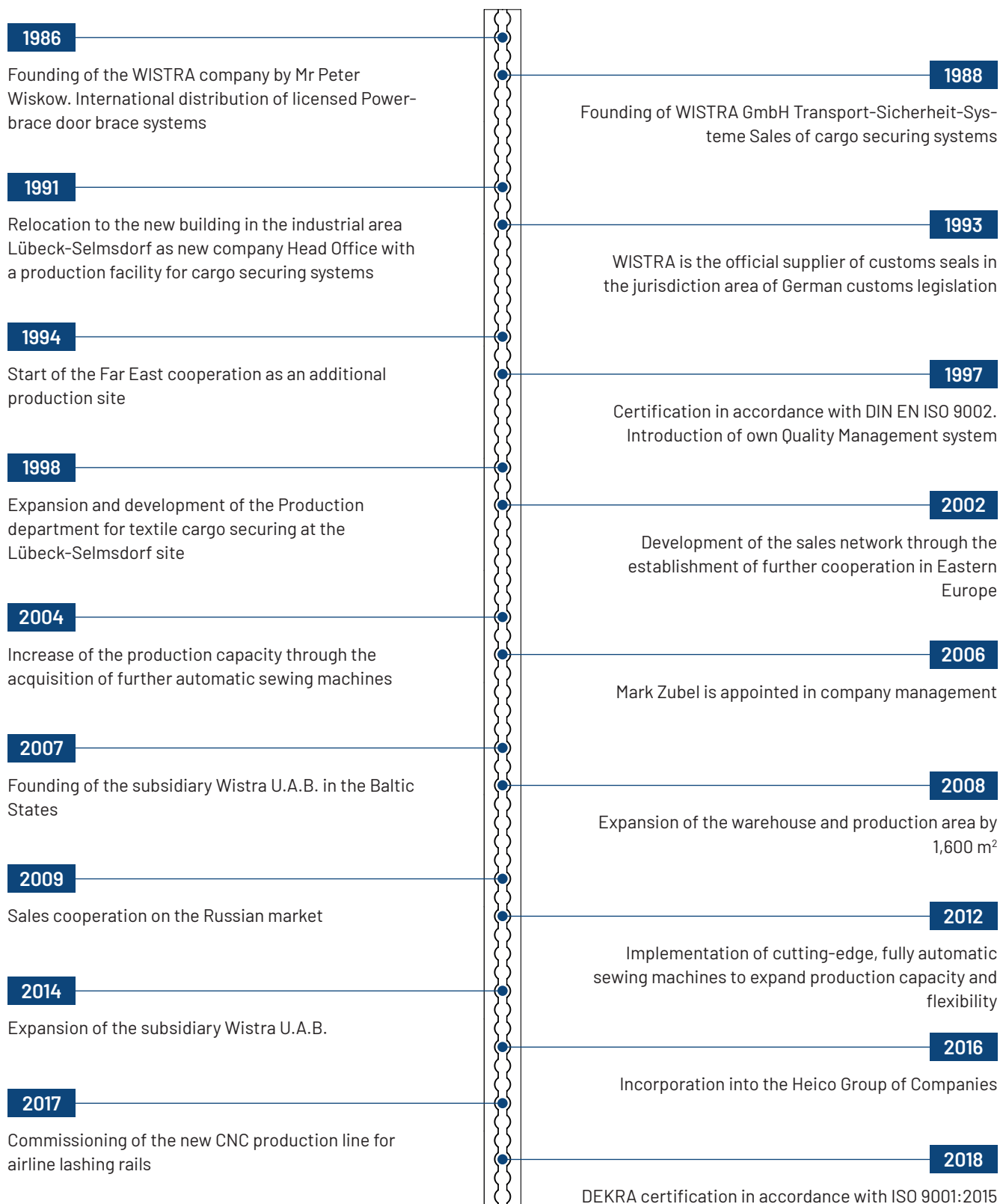



6



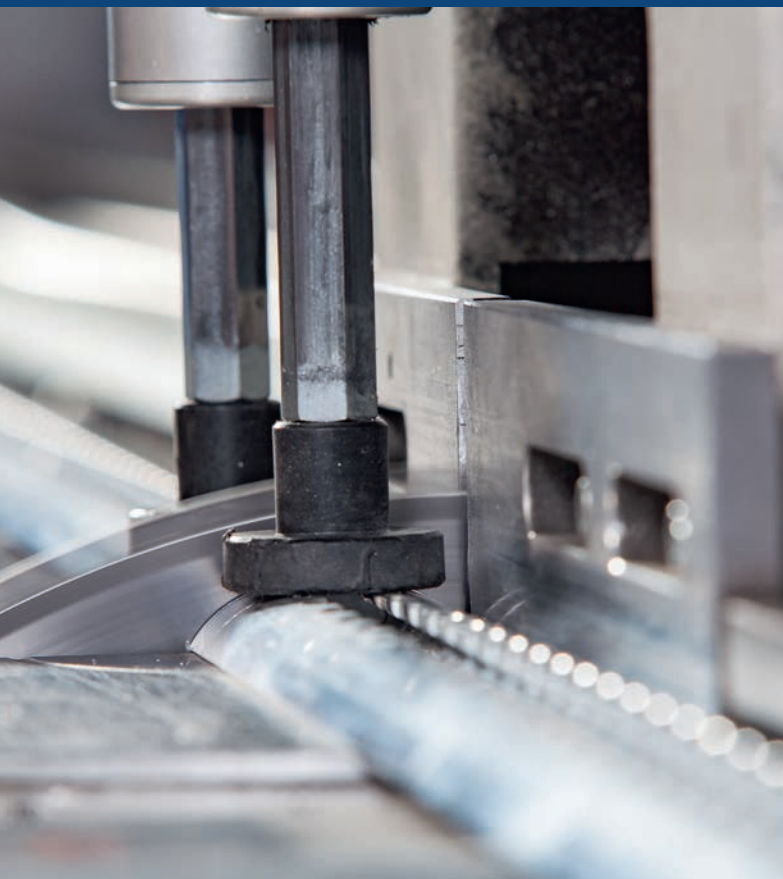

---

## Certified safety in development and production

---

### Quality

---

All products of the WISTRA product range are subjected to stringent safety tests.

Our Quality Management forms the basis for guaranteeing our consistently high quality.

Most of the products in our range are subjected to extraordinary continuous loading. Therefore, the materials processed by us always undergo extensive test series.

**This means optimum safety levels for our customers.**

---

### Production

---

Almost all products for textile and mechanical load securing are developed and designed by us.

Competent specialists ensure the installation and production of all our products in compliance with quality requirements with our modern machinery.

Years of cooperation with supplier partners worldwide make it possible for us to offer you an excellent price-performance ratio.

As a result of this cooperation, we can offer you a broad spectrum of special solutions, including the products of the "Fix Products" series, which we manufacture as the exclusive partner for Central Europe. Thanks to our own production line in Europe, we have created the necessary conditions in the sector of airline lashing rails to produce completely individual and tailor-made configurations for you - no matter how many hole pitches and radii.

You are certain to find the right solution for your individual requirements at WISTRA!

# Overview of our securing equipment

## Textile load securing

Our decades of experience and the continuous further development and supplementation of our product range enable us to offer you exceptionally designed solutions for textile load securing.

Be it air, water, rail or road – we have solutions for the individual requirements of your company regarding cargo securing.

Daily deployment under the most varied conditions proves the high degree of reliability of our products and affirms our use of the latest thermal processes.

WISTRA lashing straps are tested and manufactured to the highest standards in accordance with DIN EN 12195-2.

Our SAFEGUARD cargo securing nets are developed specifically for transport goods, adapted and made up individually. Manufacturing, marking and testing is performed in accordance with the VDI Guideline 2700 Part 3.3.

Many well-known logistics companies and global players use our SAFEGUARD cargo securing nets successfully in the areas of rail, postal, parcel service and general cargo.



example: cargo nets to hold down cargo



example: lashing strap with quick-view label

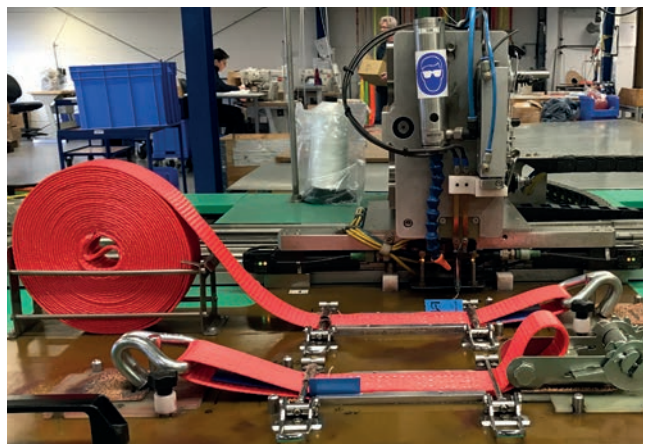

example: production of lashing straps



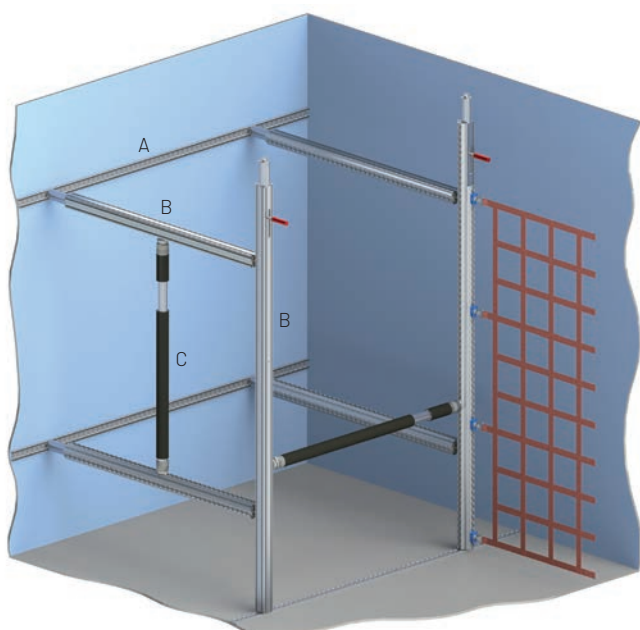

A = Airline Rails  
B = Shoring Beam  
C = Airline Beam

## Mechanical cargo securing

We have developed customs-proven load securing devices of the highest level in cooperation with the Customs Crime Institute.

The patented WISTRA shoring beam POWERSTOP resulted from this, which is used to seal cavities in vehicles and can withstand loads of up to 2.5 t.

POWERSTOP is a real Hercules among cargo securing systems and is mainly used in the combined cargo traffic on road and rail.

The rigid cargo securing devices are generally summarised in the mechanical cargo securing product group. We protect the cargo in all vehicles safely and in form-fit shape.

WISTRA has designed many of these products as unit construction systems. This enables the use of various cargo securing devices for the rails and wall panels currently installed in vehicles.



example: airline beam and shoring beam in use

## For vans and trailers

Textile load securing systems, such as lashing straps and particularly cargo nets from the SAFEGUARD series, form part of the supply range for vans and trailers. These nets are available in many standard versions proven during practical experience as well as individual solutions according to customer requirements.

WISTRA cargo nets can be used to partition cargo space, for rear cargo securing and tying down cargo. They can be fixed to the standard lashing points mounted by the vehicle manufacturer. Matching end fittings can be found in this catalogue.

All other load securing systems, such as shoring beams and lashing straps, can, of course, be adapted to vans and trailers.

WISTRA thereby offers a complete and individual solution for cargo securing in vans and trailers.

Feel free to request a solution proposal for your special transport securing system. Our qualified employees will be happy to offer advice and to prepare a corresponding offer for you.

## Security seals/theft protection

Owing to the opening of many borders for national and international trade, requirements for the safe transport of goods are increasing.

WISTRA has long been prepared for this situation and offers a broad range of security seals for your requirements regarding cargo securing.

WISTRA has assembled an extensive range of theft prevention systems in order to curb theft and manipulation. They are conceptualised in such a way that the entire means of transport is protected, at the same time preventing unauthorised access to the cargo.

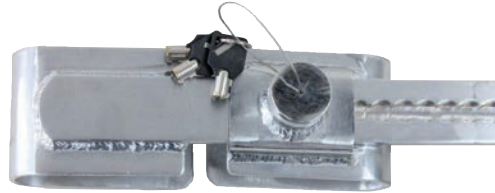
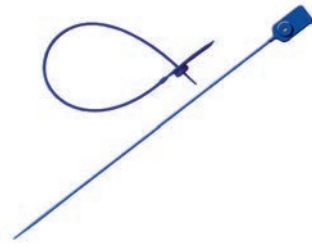

container seal and anti-theft device

## Lifting technology

The lifting technology range of WISTRA comprises round slings and lifting slings with reinforced end slings. They are only manufactured from tested material in order to meet the highest demands. Our round slings and lifting straps cover a cargo capacity of up to 10,000 kg and are manufactured according to current standards and are available in various lengths.



lifting strap and round sling

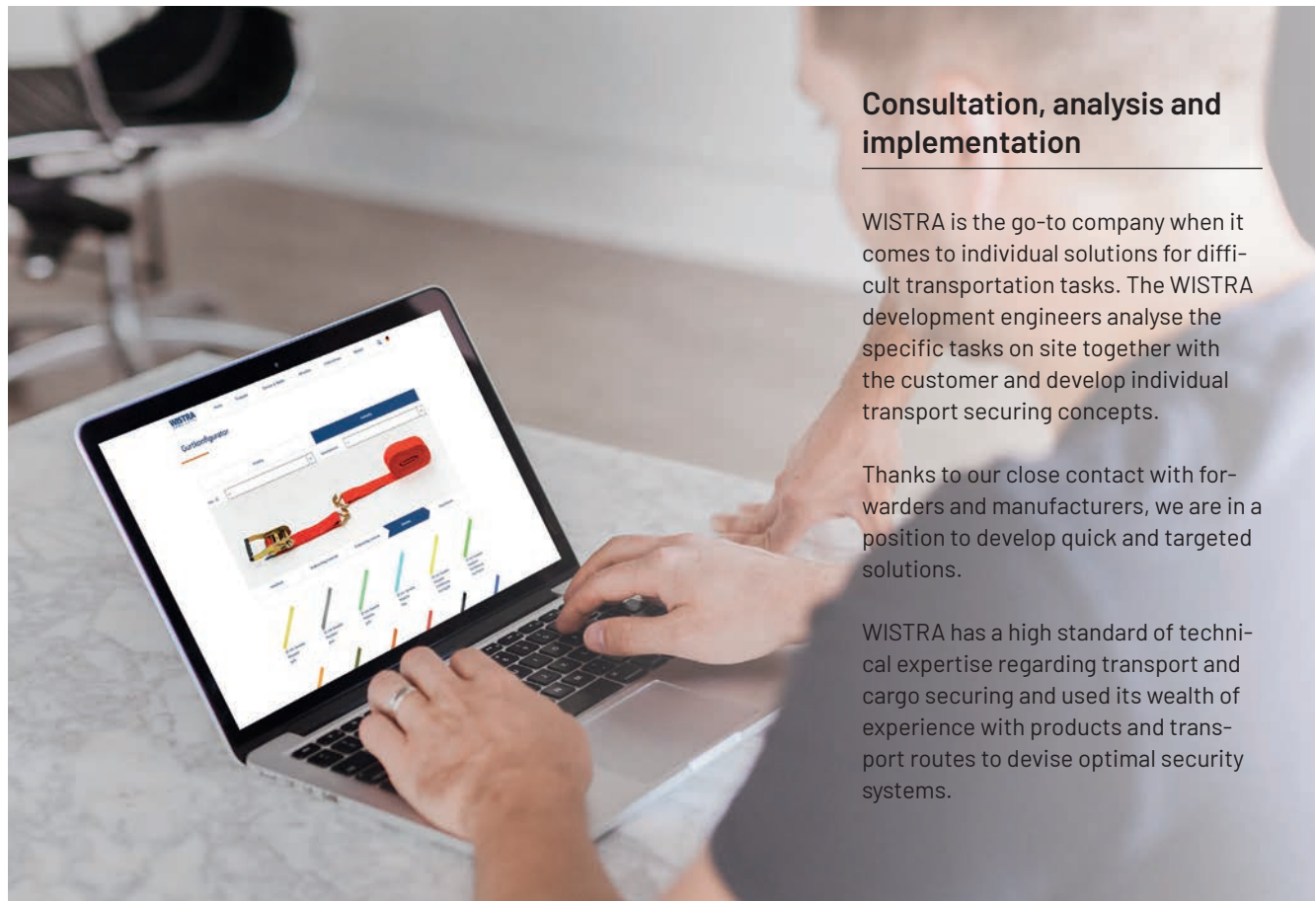

### Consultation, analysis and implementation

WISTRA is the go-to company when it comes to individual solutions for difficult transportation tasks. The WISTRA development engineers analyse the specific tasks on site together with the customer and develop individual transport securing concepts.

Thanks to our close contact with forwarders and manufacturers, we are in a position to develop quick and targeted solutions.

WISTRA has a high standard of technical expertise regarding transport and cargo securing and used its wealth of experience with products and transport routes to devise optimal security systems.



## Special requests

---

Various custom productions represent a special advantage for our customers.

WISTRA can supply lashing strap material in all colours and lengths, even if they do not appear in this catalogue.

Upon request, we can supply many items with your company logo and/or company name. Even customer-specific designs represent solvable challenges to us.

If you are unable to find an item in this catalogue, please contact us. Together, we are certain to find the right solution for you.

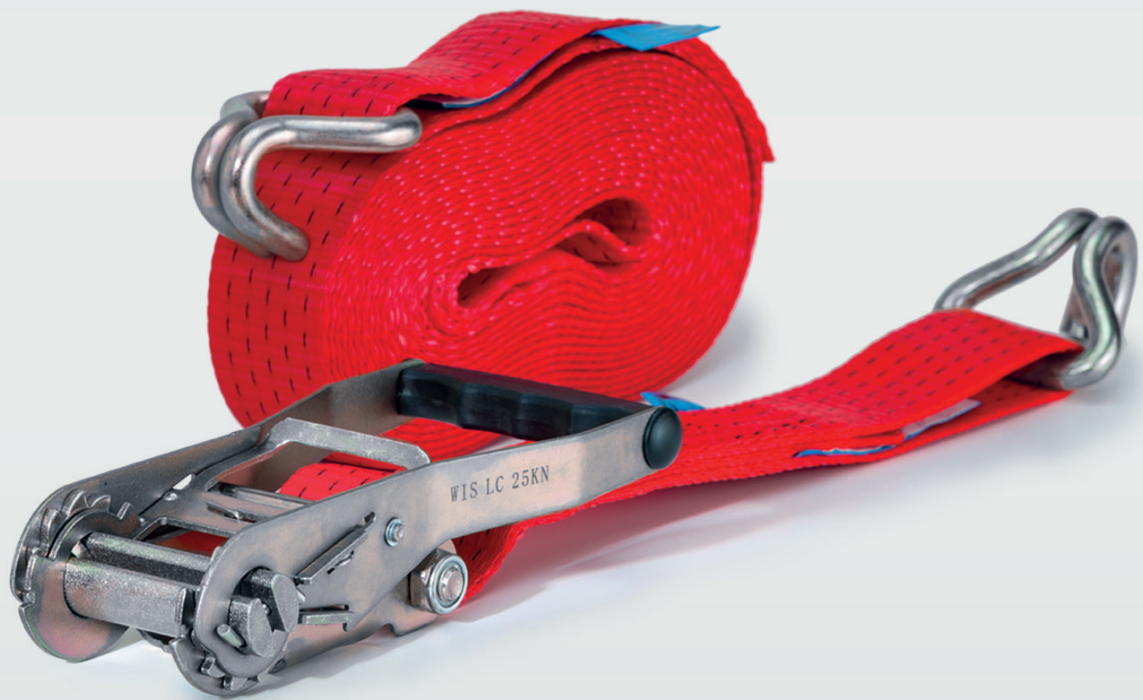

Top seller

WTR 5000-006 0.4 + 7.6 m red

More on page 13



## Cargo securing for tarpaulin and platform vehicles

## WTR 10000-067 Ratchet lashing strap



### Technical data

- > two-part – SE 0.5 m + LE 3.5 m
- two-part – SE 0.5 m + LE 7.5 m
- two-part – SE 0.5 m + LE 11.5 m
- > according to EN 12195-2
- > LC 5,000 daN with straight tension
- > with end fitting **067** (claw hook)
- > strap: min. 75 mm, yellow
- > pressure ratchet

Designation	Item number
WTR 10000-067 0.5 + 3.5 m yellow	1750535
WTR 10000-067 0.5 + 7.5 m yellow	1750575
WTR 10000-067 0.5 + 11.5 m yellow	1750591

## WTR 5000-006 Ratchet lashing strap



without imprint

### Technical data

- > two-part – SE 0.4 m + LE 7.6 m
- two-part – SE 0.4 m + LE 9.6 m
- > according to EN 12195-2
- > with Quick-View-Label
- > LC 2,500 daN with straight tension
- > STF 300 daN
- > with end fitting **006** (claw hook)
- > strap: 50 mm, red
- > pressure ratchet



with individual imprint in black as text or logo

Designation	Item number
WTR 5000-006 0.4 + 7.6 m red	11811090060476L
WTR 5000-006 0.4 + 7.6 m red "Imprint"	1507070
WTR 5000-006 0.4 + 9.6 m red	11811090060496L
WTR 5000-006 0.4 + 9.6 m red "Imprint"	1507072



many of the lashing straps are available with Quick View label



Scan QR code and watch video

[You can find the video here](#)

## WTE 5500-006 Ratchet lashing strap



without imprint



with individual imprint in black as text or logo

### Technical data

- > two-part - SE 0.4 m + LE 7.6 m
- two-part - SE 0.4 m + LE 9.6 m
- > according to EN 12195-2
- > with Quick-View-Label
- > LC 2,500 daN with straight tension
- > STF 500 daN with ratchet 822
- > with end fitting **006** (claw hook)
- > strap: 50 mm, red
- > long-lever pull ratchet

Designation	Item number
WTE 5500-006 0.4 + 7.6 m red	1500317L
WTE 5500-006 0.4 + 7.6 m red "Imprint"	1500490
WTE 5500-006 0.4 + 9.6 m red	1500323L
WTE 5500-006 0.4 + 9.6 m red "Imprint"	1500324

## WTL 5550-006 Ratchet lashing strap



without imprint



with individual imprint in black as text or logo

### Technical data

- > two-part - SE 0.5 m + LE 7.5 m
- two-part - SE 0.5 m + LE 9.5 m
- > according to EN 12195-2
- > with Quick-View-Label
- > LC 2,500 daN with straight tension
- > STF 550 daN with ratchet 818
- > with end fitting **006** (claw hook)
- > strap: 50 mm, red
- > long-lever pull ratchet

Designation	Item number
WTL 5550-006 0.5 + 7.5 m red	1502589LQV
WTL 5550-006 0.5 + 7.5 m red "Imprint"	1506995QV
WTL 5550-006 0.5 + 9.5 m red	1502591LQV
WTL 5550-006 0.5 + 9.5 m red "Imprint"	1506997QV

## WTR 5000-006 Ratchet lashing strap



### Technical data

- > short end 0.4 m
- > according to EN 12195-2
- > with Quick-View-Label
- > LC 2,500 daN with straight tension
- > STF\* (see page 130) 300 daN with ratchet 811
- > with end fitting **006** (claw hook)
- > strap: 50 mm, red
- > pressure ratchet

Designation	Item number
WTR 5000-006 SE 0.4 m red	11811090060400L

## WTE 5500-006 Ratchet lashing strap



### Technical data

- > short end 0.4 m
- > according to EN 12195-2
- > with Quick-View-Label
- > LC 2,500 daN with straight tension
- > STF\* (see page 130) 500 daN with ratchet 822
- > with end fitting **006** (claw hook)
- > strap: 50 mm, red
- > long-lever pull ratchet

Designation	Item number
WTE 5500-006 SE 0.4 m red	1500310L

## WTL 5550-006 Ratchet lashing strap



### Technical data

- > short end 0.5 m
- > according to EN 12195-2
- > with Quick-View-Label
- > LC 2,500 daN with straight tension
- > STF\* (see page 130) 550 daN with ratchet 818
- > with end fitting **006** (claw hook)
- > strap: 50 mm, red
- > long-lever pull ratchet

Designation	Item number
WTL 5550-006 SE 0.5 m red	1500714LQV

## WTR 5000-006 Ratchet lashing strap



### Technical data

- > long end – 7.6 m  
long end – 9.6 m
- > according to EN 12195-2
- > with Quick-View-Label
- > LC 2,500 daN with straight tension
- > with end fitting **006** (claw hook)
- > strap: 50 mm, red

Designation	Item number
WTR 5000-006 LE 7.6 m red	1500947LQV
WTR 5000-006 LE 9.6 m red	1500434LQV

## WTR 5000-206 Ratchet lashing strap



### Technical data

- > two-part – SE 0.4 m + LE 7.6 m
- > according to EN 12195-2
- > with Quick-View-Label
- > LC 2,500 daN with straight tension
- > STF 300 daN
- > with end fitting **206** (claw hook with safety device)
- > strap: 50 mm, red
- > pressure ratchet

Designation	Item number
WTE 5000-206 0.4 + 7.6 m red	11811092060476

16

## WTR 5000-065 Ratchet lashing strap



### Technical data

- > two-part – SE 0.4 m + LE 7.6 m
- > according to EN 12195-2
- > with Quick-View-Label
- > LC 2,500 daN with straight tension
- > STF 300 daN
- > with end fitting **065** (claw hook)
- > strap: 50 mm, red
- > pressure ratchet

Designation	Item number
WTE 5000-065 0.4 + 7.6 m red	11811090650476



## WTR 5000-075 Ratchet lashing strap



### Technical data

- > two-part – SE 0.4 m + LE 7.6 m
- > according to EN 12195-2
- > with Quick-View-Label
- > LC 2,500 daN with straight tension
- > STF 300 daN
- > with end fitting **075** (triangle snap hook)
- > strap: 50 mm, red
- > pressure ratchet

Designation	Item number
WTE 5000-075 0.4 + 7.6 m red	11811090750476

## WTR 5000-046 Ratchet lashing strap



### Technical data

- > two-part – SE 0.4 m + LE 7.6 m
- > according to EN 12195-2
- > with Quick-View-Label
- > LC 2,500 daN with straight tension
- > STF 300 daN
- > with end fitting **046** (cropped claw hook for crown outer frame)
- > strap: 50 mm, red
- > pressure ratchet

Designation	Item number
WTE 5000-046 0.4 + 7.6 m red	1504441L

## WTE 5500-206 Ratchet lashing strap



### Technical data

- > two-part – SE 0.4 m + LE 7.6 m
- > two-part – SE 0.4 m + LE 9.6 m
- > according to EN 12195-2
- > with Quick-View-Label
- > LC 2,500 daN with straight tension
- > STF 500 daN with ratchet 822
- > with end fitting **006** (claw hook with safety device)
- > strap: 50 mm, red
- > long-lever pull ratchet

Designation	Item number
WTE 5500-206 0.4 + 7.6 m red	1500524
WTE 5500-206 0.4 + 9.6 m red	1500553

## WTL 5550-206 Ratchet lashing strap



### Technical data

- > two-part – SE 0.5 m + LE 7.5 m / two-part – SE 0.5 m + LE 9.5 m
- > according to EN 12195-2
- > with Quick-View-Label
- > LC 2,500 daN with straight tension
- > STF 550 daN with ratchet 818
- > with end fitting **206** (claw hook with safety device)
- > strap: 50 mm, red
- > with imprint long end
- > long-lever pull ratchet

Designation	Item number
WTL 5550-206 0.5 + 7.5 m red	1258548
WTL 5550-206 0.5 + 9.5 m red	1502623

## WTR 4000-006 Ratchet lashing strap



### Technical data

- > two-part – SE 0.4 m + LE 7.6 m / two-part – SE 0.4 m + LE 9.6 m
- > according to EN 12195-2
- > with Quick-View-Label
- > LC 2,000 daN with straight tension
- > STF 300 daN
- > with end fitting **006** (claw hook)
- > strap: 50 mm, yellow
- > pressure ratchet

Designation	Item number
WTR 4000-006 0.4 + 7.6 m yellow	11811060060476L
WTR 4000-006 0.4 + 9.6 m yellow	11811060060496L

## WTR 2000-520 Ratchet lashing strap



### Technical data

- > two-part – SE 0.5 m + LE 3.5 m / two-part – SE 0.5 m + LE 5.5 m / two-part – SE 0.5 m + LE 7.5 m
- > according to EN 12195-2
- > with Quick-View-Label
- > LC 1,000 daN with straight tension
- > STF 240 daN
- > with end fitting **520** (claw hook)
- > strap: 35 mm, orange
- > pressure ratchet

Designation	Item number
WTR 2000-520 0.5 + 3.5 m orange	1350605
WTR 2000-520 0.5 + 5.5 m orange	1350607
WTR 2000-520 0.5 + 7.5 m orange	1350609

## WTR 2000 Ratchet lashing strap

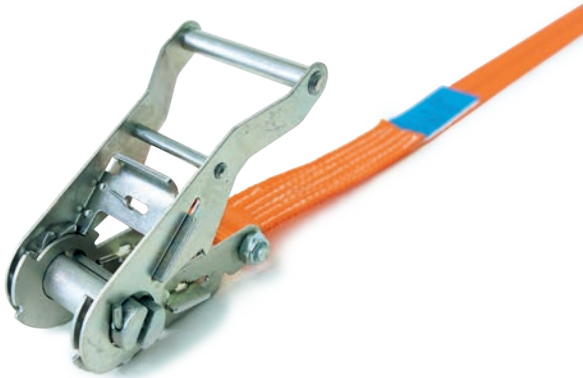

### Technical data

- > single-part – 3.0 m / 5.0 m / 8.0 m
- > according to EN 12195-2
- > lashing capacity LC 2000 daN in strapping
- > STF 480 daN
- > strap: 35 mm, orange
- > pressure ratchet

Designation	Item number
WTR 2000 single-part 3.0 m orange	1350995
WTR 2000 single-part 5.0 m orange	1350997
WTR 2000 single-part 8.0 m orange	1351000

## WTR 2200-520 Ratchet lashing strap



### Technical data

- > two-part – SE 0.5 m + LE 5.5 m
- > two-part – SE 0.5 m + LE 7.5 m
- > according to EN 12195-2
- > with Quick-View-Label
- > LC 1,000 daN with straight tension
- > STF 200 daN
- > with end fitting **520** (claw hook)
- > strap: 35 mm, orange
- > pressure ratchet

Designation	Item number
WTR 2200-520 0.5 + 5.5 m orange	1353004
WTR 2200-520 0.5 + 7.5 m orange	1353005

---

## Edge protection 5500



---

### Technical data

- > with reinforcement and chamfer
- > for strap widths up to 65 mm
- > colour: black
- > material: plastic
- > practical for paper roll transports or similar goods

Designation	Item number
Edge protection black 65 mm	165500000040

---

## Edge protection 6600



---

### Technical data

- > with chamfer
- > for strap widths up to 85 mm
- > colour: red
- > material: plastic
- > for the flexible use of sensitive goods up to the transport of building materials

Designation	Item number
Edge protection red 85 mm	166600000040

---

## Edge protection 2200



---

### Technical data

- > light version
- > for strap widths up to 100 mm
- > colour: white
- > material: plastic

Designation	Item number
Edge protection white 100 mm	162200000240

## Edge protection 3000



### Technical data

- > lengths: 800 mm / 1,000 mm / 1,200 mm / 6,000 mm
- > format: 190 x 190 mm
- > colour: orange
- > material: plastic
- > edge protector for the transport of building material or similar goods

Designation	Item number
Edge protection 190 x 190 orange 800 mm	16300040-0800
Edge protection 190 x 190 orange 1,000 mm	16300040-1000
Edge protection 190 x 190 orange 1,200 mm	16300040-1200
Edge protection 190 x 190 orange 6,000 mm	16300040-6000

## Edge protection 3001



### Technical data

- > lengths: 800 mm / 1,000 mm / 1,200 mm / 6,000 mm
- > format: 190 x 190 mm
- > colour: black
- > material: plastic
- > edge protector for the transport of building material or similar goods

Designation	Item number
Edge protection 190 x 190 black 800 mm	16300140-0800
Edge protection 190 x 190 black 1,000 mm	16300140-1000
Edge protection 190 x 190 black 1,200 mm	16300140-1200
Edge protection 190 x 190 black 6,000 mm	16300140-6000

## Edge protection "Connect 1616"

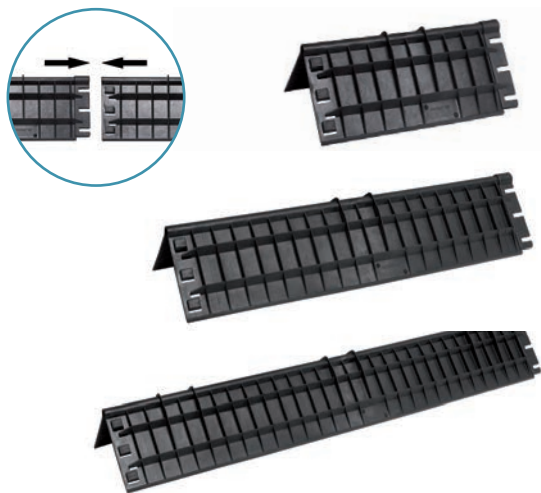

### Technical data

- > lengths: 400 mm / 800 mm / 1,200 mm
- > format: 170 x 170 mm
- > colour: black
- > material: plastic

Designation	Item number
Edge protection KP Connect black 400 mm	1616040
Edge protection KP Connect black 800 mm	1616080
Edge protection KP Connect black 1,200 mm	1616120

*Special feature: Different lengths can easily be connected and separated again.*

## Edge protection / ratchet pad 1630



### Technical data

- > for strap widths up to 50 mm
- > colour: transparent
- > material: plastic, polyurethan
- > material thickness: 3,8 mm

Designation	Item number
Edge protection ratchet pad 50 mm, slotted	163003

*Special feature: The soft material adapts well to goods with round shapes and thus protects the cargo from being scratched by the ratchet or the strap.*

## Edge protection hose 1020 rubberised

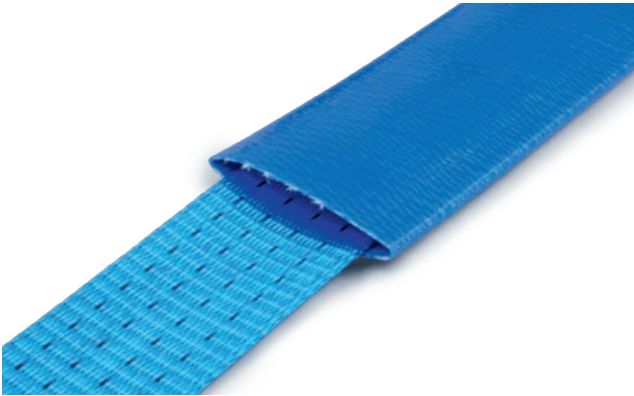

### Technical data

- > for strap widths up to 50 mm
- > material: PVC
- > surface: rubberised
- > colour: blue
- > sold by the metre
- > material thickness: approx. 1,2 mm,  
exterior width: approx. 66 mm

Designation	Item number
Edge protection hose 50 mm rubberised	161020000040

*Special feature: The soft material adapts well to goods with round shapes and thus protects the cargo from being scratched by the strap.*

## Edge protection hose 1020 polyester

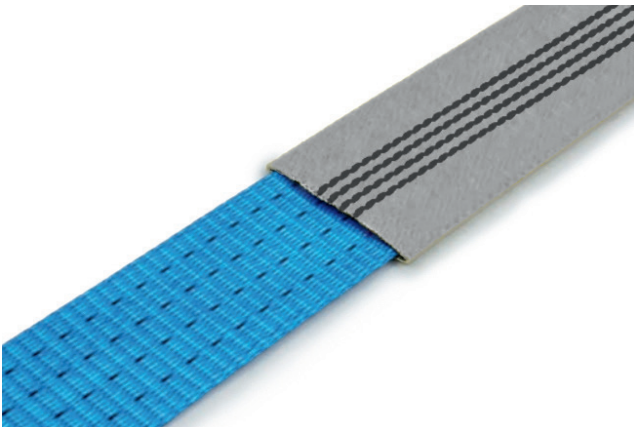

### Technical data

- > for strap widths up to 50 mm
- > material: polyester
- > colour: yellow
- > sold by the metre
- > material thickness: approx. 0,7 mm,  
exterior width: approx. 67 mm

Designation	Item number
Edge protection hose 50 mm PES yellow	161020000073

*Special feature: The soft material adapts well to goods with round shapes and thus protects the cargo from being scratched by the strap.*

## Edge protection hose 1021

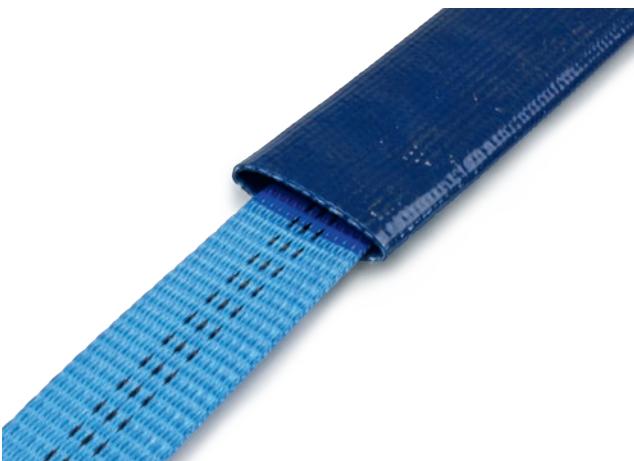

### Technical data

- > for strap widths up to 40 mm
- > material: PVC
- > surface: rubberised
- > colour: blue
- > sold by the metre
- > material thickness: approx. 2 mm,  
exterior width: approx. 52 mm

Designation	Item number
Edge protection tube 35 mm rubberised	161021000040

*Special feature: The soft material adapts well to goods with round shapes and thus protects the cargo from being scratched by the strap.*

## Wheel chock

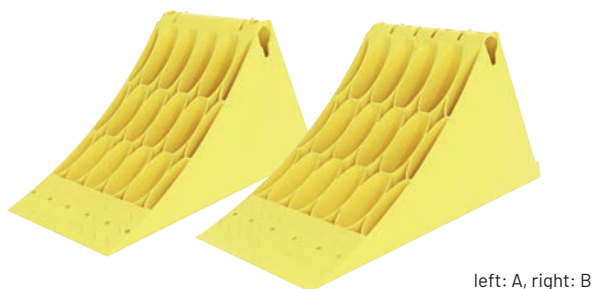

left: A, right: B

### Technical data

- > suitable for tractor units, semi-trailers, trucks and trailers
- > material: plastic PP (recyclable)
- > colour: yellow
- > UV- and weather-resistant between -30°C and +50°C
- > central handle for easy handling
- > maximum tyre radius A: 460 mm
- > maximum tyre radius B: 555 mm
- > weight A: 0.75 kg
- > weight B: 1.19 kg

Designation	Item number
Wedge pad yellow 467 x 198 x 225 mm	393001
Wedge pad yellow 383 x 160 x 190 mm	393002

## Wheel chock holder, round, galvanized with screw



### Technical data

- > length: 250 mm
- > diameter: 21 mm
- > weight: 0.52 kg

Designation	Item number
Roundy	393006

## Hot galvanized chock holder

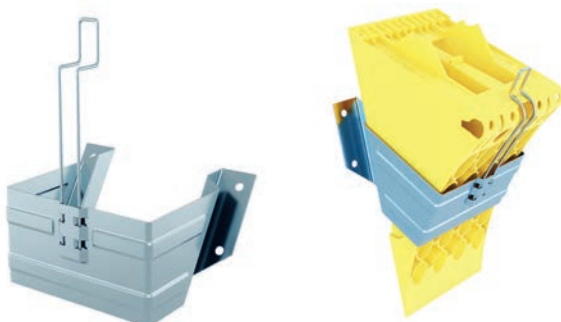

### Technical data

- > bracket with retaining spring for wheel chock #393001, #393002
- > material: Sheet steel, hot-dip galvanized
- > L x W x H small: 166 x 120 x 174 mm
- > L x W x H big: 207 x 162 x 231 mm

Designation	Item number
Wedge bracket for pad #393001	393007
Wedge bracket for pad #393002	393008



## Anti-slip mat



### Technical data

- > material: PU bound rubber granulate
- > material thickness: 8 mm
- > coefficient of sliding friction:  $\mu$  0.6
- > colour: black
- > weight: approx. 7.2 kg / m<sup>2</sup>

### Anti-slip mat as pad:

- > size: 130 mm x 110 mm
- size: 300 mm x 200 mm

Designation	Item number
RH mat 8 x 110 x 130 mm	161108013081
RH mat 8 x 200 x 300 mm	162008030081

### Anti-slip mat on a roll:

- > size: 5,000 mm x 250 mm
- size: 5,000 mm x 500 mm
- size: 10,000 mm x 1,250 mm

Designation	Item number
RH mat 8 x 250 x 5000 mm	162508500081
RH mat 8 x 500 x 5000 mm	165008500081
RH mat 8 x 1250 x 10000 mm	161250810081



## Lashing strap retractor



black powder-coated



stainless steel version

### Technical data

- > for strap widths up to 50 mm
- > material: steel, black powder-coated or stainless steel

Designation	Item number
Lashing strap retractor WIS black powder-coated	160020000000
WIS lashing strap retractor stainless steel version	160020000030

## Longitudinal bar 6030/3009

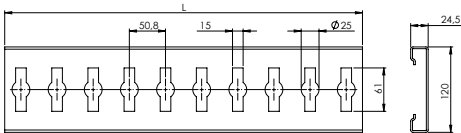
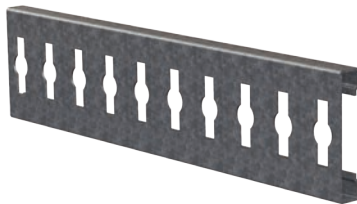

### Technical data

- > material: steel, hot-dip galvanised

Designation	Item number
Longitudinal bar 6030/3009 steel 3500 mm	226030093500

*Special feature: Combined with a decking beam, it is possible to achieve high blocking forces on a semi-trailer / curtainsider. Lashing straps can also be used with appropriate fittings.*

## Longitudinal bar 2104

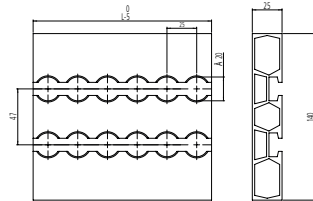
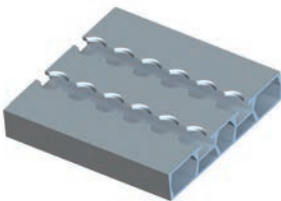

### Technical data

- > material: aluminium

Designation	Item number
Longitudinal bar 25 x 140 3500 mm	22210400-3500

*Special feature: Combined with an Airline Beam, it is possible to achieve high blocking forces on a semi-trailer / curtainsider. Lashing straps can also be used with appropriate fittings.*

## Adapter belt as parking device



### Technical data

- > adapter strap for hanging up / storage of short ends or intermediate wall closures on side walls and tarpaulin frame
- > strap width: 25 mm
- > colour: red
- > with reversing loop and tarpaulin frame hooks

Designation	Item number
Parking device for battens	1250705

## Aluminium parting wall lock 7453

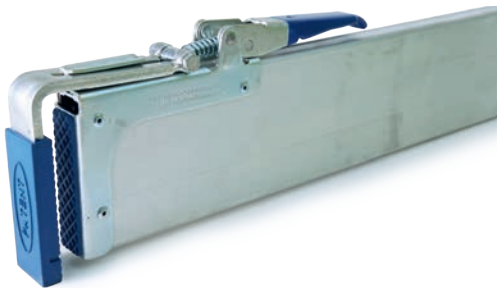

### Technical data

- > with folded steel end piece
- > application range: 2,400 mm - 2,700 mm
- > max. blocking force: BC 400 daN for uniform area loading up to 2,700 mm

Designation	Item number
Between aluminium 2400 - 2700	237453000020

## Steel parting wall lock S4



### Technical data

- > application range: 1,920 mm - 2,720 mm
- > equipped with protective caps in the end pieces from inside and outside

Designation	Item number
Between steel 1920-2720 S4	237430000012

---

## Complete end piece



---

### Technical data

> for intermediate wall lock 237452900020

Designation	Item number
Between KT end piece for aluminium profile with cover	237450000012

---

## Protection cap



---

### Technical data

> for intermediate wall lock 237452900020

Designation	Item number
Between protective cap end piece ZWV 7452	237459900140

---

## Push-in cap as slip protection



---

### Technical data

> for intermediate wall lock 237452900020

Designation	Item number
Between protective cap end piece ZWV 7452	237459900440

## Double-deck system curtainsider



Scan QR code  
and watch video

[You can find the  
video here](#)



- › optimal utilisation of the cargo volume by creating 33 Euro pallet positions on the 2<sup>nd</sup> loading level, goods of different heights can be loaded without any problems
- › simple self-explanatory operation
- › height-adjustable in 50 mm increments
- › Unused support beams are parked between the stanchions.
- › longitudinal locking of the supporting beams to stabilise the vehicle body
- › The loading surface for the pallets is approx. 15 mm below the upper edge of the longitudinal beam and thus serves as a pallet stop. No slipping out of the pallets into the tarpaulin.
- › positive cargo securing is also possible with axle load-optimised partial loading by means of additional load-bearing beams or longitudinal beams
- › The maximum load capacity of the positive fit with uniform loading is 500 daN. A prerequisite is sufficient body strength (Code XL certificate for standard semi-trailers).
- › Total loading capacity of the 2<sup>nd</sup> loading level is usually 6,000 kg to 11,000 kg (depending on the trailer manufacturer's specifications).
- › max. pallet weight 275 – 500 kg
- › Additional diagonal lashing is possible.
- › DDS-CS plank pockets can be installed in the double-decking pillars and adjusted in height.

**Note: The maximum load capacity of the 2<sup>nd</sup> loading level is specified by the manufacturer of the semi-trailer or vehicle. A subsequent installation of the system not approved by the manufacturer can lead to the loss of the XL certificate and/or the factory guarantee.**

### WISTRA Accessories

#### Bow base support for Double-Decking-System

Designation	Part No.
Tarpaulin frame brackets CS	228010001



## Double-deck system curtainsider with 5 pairs of stanchions

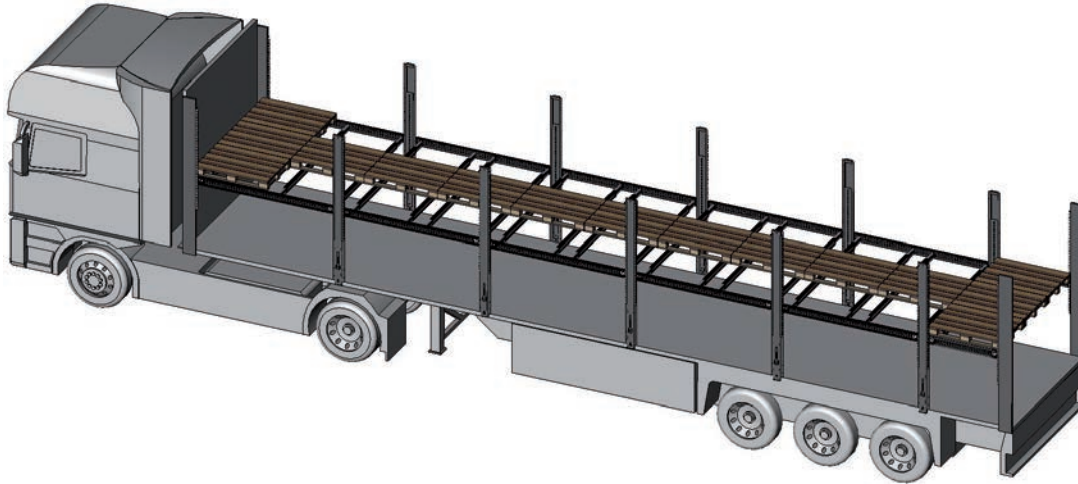

## Longitudinal bar for double-deck curtainsider system



### Technical data

- > material: steel, KTL-coated
- > load capacity for 500 kg/Euro pallet
- > max. load 1,500 kg
- > profile length of 2,200 mm for application range of 2,225...2,250 mm +/- 5
- > profile length of 1,070 mm for application range of 1,095...1,120 mm +/- 5
- > end pieces movable by 20 mm on both sides

**Attention:** When placing your order, please specify the profile length and version.

Designation	Item number
Longitudinal beam CS with double pin 2,200 mm	228000970115
Longitudinal beam CS with double pin 2,200 mm	228000970215

## Aluminium carrier bar for double-deck curtainsider system



### Technical data

- > size: 40 mm x 105 mm
- > complete pull-out on both sides with length adjustment
- > load capacity for 500 kg/Euro pallet
- > max. load 1,000 kg
- > profile length of 2,000 mm for application range of 2,220...2,510 mm +/- 5
- > end pieces movable by 20 mm on both sides

Designation	Item number
Support beam CS with double pin 2,000 mm	228000870020

## Double-deck system "light" curtainsider with 3 pairs of stanchions

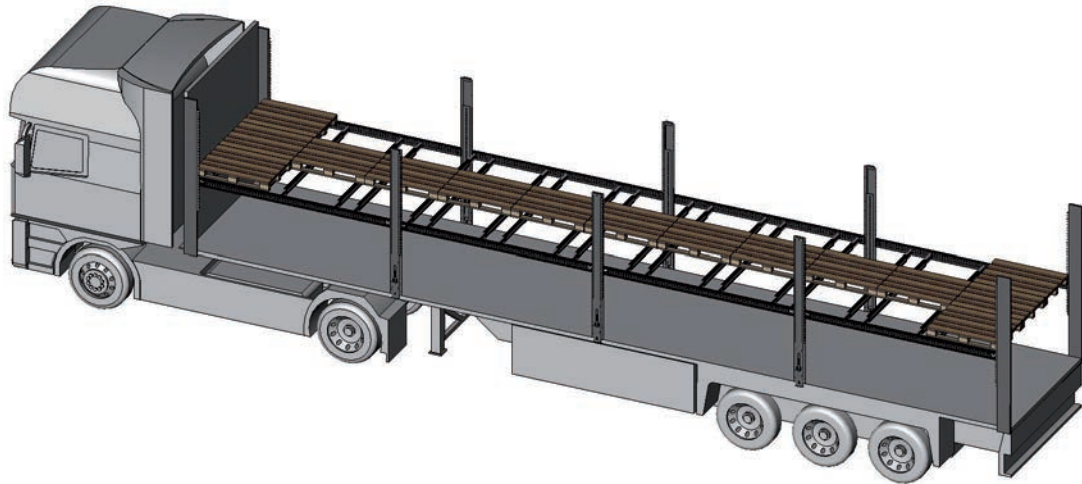

## Longitudinal bar for double-deck curtainsider system



### Technical data

- > material: steel, KTL-coated
- > load capacity for 2,300 kg/stanchion field
- > max. load 1,150 kg
- > profile length of 3,120 mm for application range of 3,145...3,170 mm +/- 5
- > end pieces movable by 20 mm on both sides

**Attention:** When placing your order, please specify the profile length and version.

Designation	Item number
Longitudinal beam CS with double pin 3,120 mm	228000970715

## Aluminium carrier bar for double-deck curtainsider system



### Technical data

- > size: 40 mm x 105 mm
- > complete pull-out on both sides with length adjustment
- > load capacity for 500 kg/Euro pallet
- > max. load 1,000 kg
- > profile length of 2,000 mm for application range of 2,220...2,510 mm +/- 5
- > end pieces movable by 20 mm on both sides

Designation	Item number
Support beam CS with double pin 2,000 mm	228000870020

## FIX STRAP – simplifies the use of tension straps



### Simple but ingenious solution

With the "FIX STRAP" load securing system, the lashing strap hangs on rails directly under the roof of the semi-trailer with the aid of rubber ropes. The hook on one side is pulled down and fixed to a lashing point. Thanks to the rubber rope, the hook remains fixed. After loading, the lashing strap is pulled over the cargo, just like a normal lashing strap. During unloading, the ratchet is opened and the rubber ropes pull the lashing strap under the ceiling of the hold. This makes unloading and loading easier.

Since the rubber ropes with holders run on rails on the roof of the semi-trailer, you can simply pull the lashing strap to where it is needed.

### Advantages:

- climbing onto the loading area and cargo to apply a lashing strap is avoided
- throwing of lashing straps over the cargo is avoided
- time saving during loading and unloading due to flexible positioning of the system on the rails
- simple and safe
- FIX STRAP uses the same suspension system as the FIX ROAD load securing system, making it easy to switch.

32



Rated best in regard to work safety\*



8 loads per week gives a payback period of 5 weeks



Meets the loading requirements of the EU

\*HSE Health and Safety Executive, UK

### Available as a set

Designation	Item number
Belt lift system SET 14.4 m 12 bungees	160400
Belt lift system SET 7.2 m 6 bungees	160401
Belt lift system SET for fixed installation for 1 belt	160402

### Accessories / spare parts

Designation	Item number
FIX-Mini 0,4 x 2,8 m	160200
FIX-Bungee Fixed sys. d19/375 colour 8 mm	160211
FIX-Slide	160220
FIX-Bungee sys. d19/375 colour 8 mm	160210



## FIX ROAD



### The easy way of securing cargo

There is a simple solution with which you can avoid the time-consuming and often complicated securing of cargo. "FIX ROAD" is a cargo securing system that is quick, safe and easy to use. "FIX ROAD" consists of a hard-wearing tarpaulin, which is attached beneath the roof of the semi-trailer with rubber ropes. The tarpaulin, which runs on rails, can be quickly and easily pulled over the cargo. There is no longer any need to climb onto the cargo to attach straps and edge protection. The tarpaulin covers the transported goods evenly and is then tensioned with the aid of integrated lashing straps.

#### In accordance with EU Directives

"FIX ROAD" is not only user-friendly, it also protects the cargo. It is suitable for securing most types of goods, from rolls, pallets, bales, web and sheet goods to sacks and octabins. "FIX ROAD" makes securing the cargo easier, especially for bulky and cargo of different sizes. Because the tarpaulin is attached to the roof, the semi-trailer is ready for loading at all times. "FIX ROAD" complies with the applicable EU safety guidelines (VDI 2700 / cargo securing on road vehicles and DIN standards EN 12195-2 / lashing straps made of synthetic

fibres). The "FIX ROAD" tarpaulin has woven reinforcements and hemmed-in safety straps. It has a permissible LC of 2,500 daN.

With "FIX ROAD", you no longer need to climb onto the cargo to secure it. The tarpaulin can be easily and quickly pulled over the cargo. After all, it only weighs just over 40 kg. Bulky cargo can be secured quickly and easily with the "FIX ROAD" tarpaulin because it covers the cargo evenly. Time-consuming considerations on how to secure the transported goods are not necessary. With "FIX ROAD", the lashing straps are simply tensioned downwards into the lashing points on the bed.



**Many advantages**

- > quick and easy to use
- > soft and easily mouldable, even in cold and rough weather
- > hard-wearing material with UV protection
- > does not damage the goods
- > protects against rain and dirt
- > makes edge protection superfluous
- > low weight (a medium-sized tarpaulin weighs about 40 kg)
- > long service life even under difficult conditions
- > advertising material can be printed or sewn on
- > saves time when securing the cargo
- > fits different types of goods
- > enables a longer and/or wider protective tarpaulin (for better protection against e.g. rain)
- > DEKRA-approved



patented



tested and approved  
by DEKRA



high sustainability  
and long lifespan



## Daken Welvet 600 tool box

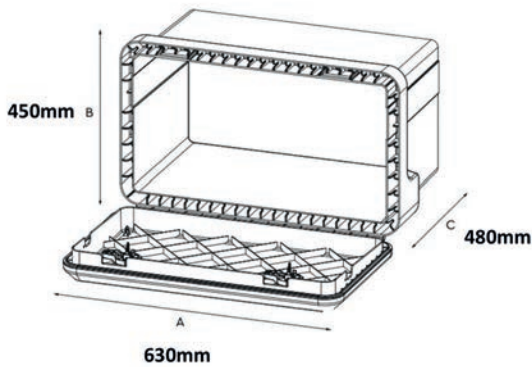

### Technical data

- > material: plastic (polypropylene)
- > colour: black
- > size: 630 x 450 x 480 mm
- > made by injection molding
- > reinforced structure for high durability and long lifespan
- > 2 locks with lock cylinder for maximum safety against theft and abuse
- > PVC inner seal against dust and water ingress
- > smooth inner surface
- > high-grade plastic materials with high resistance to UV rays, fire, lubricating oils, carbon hydrogen, high and low temperatures
- > continuous hinge
- > volume: approx. 78.5 l, weight: 8 kg, payload: max. 60 kg
- > 4 keys
- > made in Italy
- > CA-Zertifizierung als seitlicher Anfahrerschutz
- > TÜV RHEINLAND approvals: Resistance to water and dust

Designation	Item number
Daken Welvet 600 630 x 450 x 480 mm	160500

## Daken Welvet 800 tool box

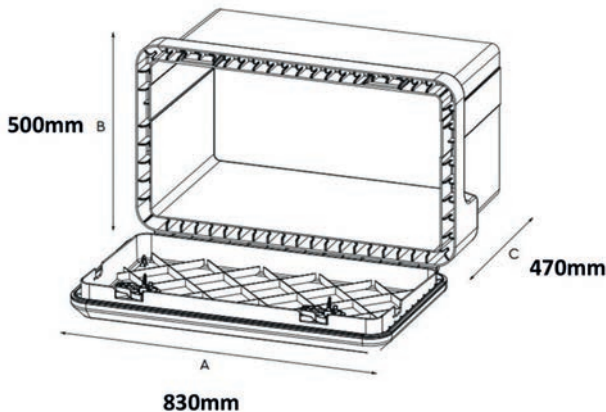

### Technical data

- > material: plastic (polypropylene)
- > colour: black
- > size: 830 x 500 x 470 mm
- > made by injection molding
- > reinforced structure for high durability and long lifespan
- > 2 locks with lock cylinder for maximum safety against theft and abuse
- > PVC inner seal against dust and water ingress
- > smooth inner surface
- > high-grade plastic materials with high resistance to UV rays, fire, lubricating oils, carbon hydrogen, high and low temperatures
- > continuous hinge
- > volume: approx. 120 l, weight: 10.5 kg, payload: max. 65 kg
- > 4 keys
- > made in Italy
- > CA certification as lateral collision protection
- > TÜV RHEINLAND approvals: Resistance to water and dust

Designation	Item number
Daken Welvet 800 830 x 500 x 470 mm	160501

## Daken Velvet 1000 tool box

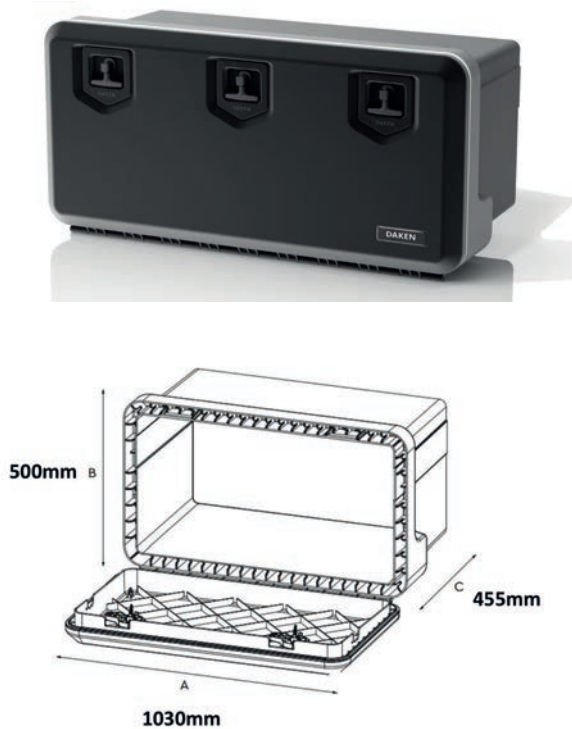

### Technical data

- > material: plastic (polypropylene)
- > colour: black
- > size: 1,030 x 500 x 455 mm
- > made by injection molding
- > reinforced structure for high durability and long lifespan
- > lock with lock cylinder for maximum safety against theft and abuse
- > PVC inner seal against dust and water ingress
- > smooth inner surface
- > high-grade plastic materials with high resistance to UV rays, fire, lubricating oils, carbon hydrogen, high and low temperatures
- > continuous hinge
- > volume: approx. 155.5 l, weight: 13 kg, payload: max. 70 kg
- > 6 keys
- > made in Italy
- > CA certification as lateral collision protection
- > TÜV RHEINLAND approvals: Resistance to water and dust

Designation	Item number
Daken Velvet 1000 1030 x 500 x 455 mm	160502

## Daken Just 500-R tool box



### Technical data

- > material: plastic (polypropylene)
- > colour: black
- > size: 500 x 350 x 300 mm
- > lockable pressure lock
- > dust and splash-proof
- > shockproof outer shape
- > UV stable
- > volume: approx. 30.5 l
- > weight: 3.6 kg
- > CA certification as lateral collision protection
- > TÜV RHEINLAND approvals: Resistance to water and dust

Designation	Item number
Daken Just-R 500 x 350 x 300 mm	160503

## Daken universal holder

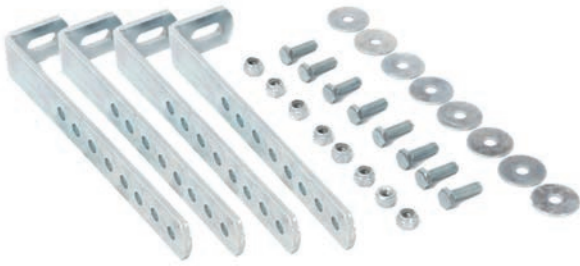

### Technical data

The hot dip galvanized universal holder for Daken Velvet Just tool boxes is used for fastening underneath a loading surface on the vehicle.

- > for Daken Velvet Just tool box
- > material: 6 mm
- > weight: 1.7 kg
- > made in Italy

Designation	Item number
Daken universal holder	160505

## Daken Blackit 2 drawbar box

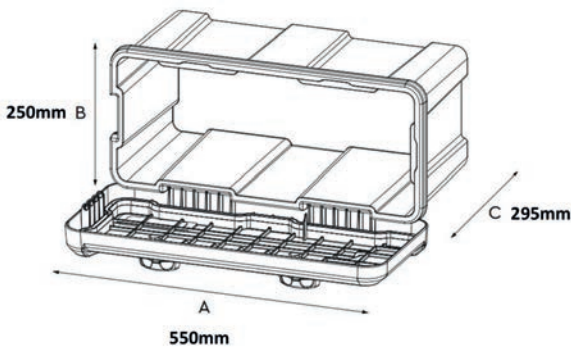

### Technical data

- > material: plastic (polypropylene)
- > colour: grau
- > size: 550 x 250 x 295 mm
- > made by injection molding
- > reinforced structure for high durability and long lifespan
- > 2 locks with lock cylinder for maximum safety against theft and abuse
- > optimal for mounting on the drawbar of a trailer
- > overlapping lid and PVC inner gasket against dust and water ingress
- > high-grade plastic materials with high resistance to UV rays, fire, lubricating oils, carbon hydrogen, high and low temperatures
- > stable hinges
- > volume: approx. 23 23 l
- > weight: 2.8 kg
- > 4 keys
- > made in Italy
- > CA certification as lateral collision protection
- > TÜV RHEINLAND approvals: Resistance to water and dust

Designation	Item number
Daken Blackit 550 630 x 250 x 295 mm	160504

## Daken square drawbar holder

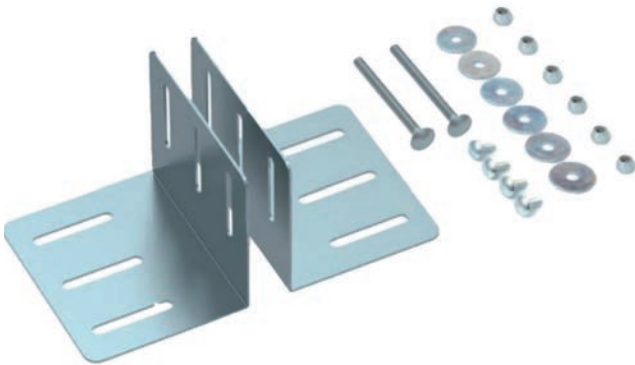

### Technical data

The cold galvanized square handle bar holder for Daken Blackit 2 tool boxes are used to attach tool boxes on the drawbar.

- > for Daken Blackit 2 drawbar box
- > material thickness: 2 mm
- > weight: 1.2 kg
- > made in Italy

Designation	Item number
Daken square drawbar holder	160506

## Daken V-drawbar holder



### Technical data

The cold galvanized V-drawbar holder for Daken Blackit 2 tool boxes are used to attach to a V-drawbar.

- > for Daken Blackit 2 drawbar box
- > material thickness: 6 mm
- > weight: 0.7 kg
- > made in Italy

Designation	Item number
Daken V-drawbar holder	160507

## Daken front wall holder



### Technical data

The cold galvanized front wall bracket for Daken Blackit 2 tool boxes attaches to a trailer.

- > for Daken Blackit 2 drawbar box
- > material thickness: 2 mm
- > weight: 1.6 kg
- > made in Italy

Designation	Item number
Daken front wall holder	160508

## Daken Adamant fire extinguisher box



### Technical data

- > material: plastic (polypropylene)
- > colour: rot
- > size: 310 x 610 x 247 mm
- > made by injection molding
- > can be used for 6 kg fire extinguishers with a diameter from 150 to 170 mm
- > installation can be horizontal or vertical
- > PVC inner seal against dust and water ingress with viewing window (with OR seal for optimal water resistance)
- > 2 ergonomic nylon closures
- > lockable by padlock or sealable for maximum security against theft and abuse
- > stable hinges
- > weight: 3.5 kg
- > made in Italy

**The fire extinguisher is not included.**

Designation	Item number
Daken Adamant 310 x 610 x 247 mm	160509

## Daken Strike Feuerlöscherkasten



### Technical data

- > material: plastic (polypropylene)
- > colour: rot, schwarz
- > size: 287 x 600 x 220 mm
- > made by injection molding
- > can be used for 6 kg fire extinguishers with a diameter from 150 to 170 mm
- > installation can be horizontal or vertical
- > PVC inner seal against dust and water ingress with viewing window (with OR seal for optimal water resistance)
- > 2 ergonomic nylon closures
- > blocking kit with bayonet lock consisting of: Nylon clamping ring and PVC locking spring with 4 holes
- > lockable by padlock or sealable for maximum security against theft and abuse
- > stable hinges
- > weight: 1.9 kg
- > made in Italy

**The fire extinguisher is not included.**

Designation	Item number
Daken Strike 287 x 600 x 220 mm	160510



## Daken Stopper truck door arrester



### Technical data

- > size: 310 x 56.5 x 414 mm
- > nylon body with steel springs
- > solid structure with high dust and water resistance
- > spring system for a perfect hold on the tailgate
- > ergonomic handle with non-slip grip
- > weight: 1.5 kg
- > made in Italy

*Since the handle can be rotated 360° it can be mounted on both sides of the vehicle.*

Designation	Item number
Daken Stopper 310 x 56,5 x 414 mm	160511

## Daken "Stopper" holder



### Technical data

- > hot dip galvanized holder for the Daken "Stopper" door stopper
- > size: 150 x 190 x 40 mm
- > material thickness: 3 mm
- > weight: 0.9 kg
- > made in Italy

Designation	Item number
Daken Stopper holder 150 x 190 x 40 mm	160512



Top seller

**Adjustable round shoring beam aluminium**

---

*More on page 54*



**Cargo securing for  
box trucks**

## Aluminium track with pins 4710

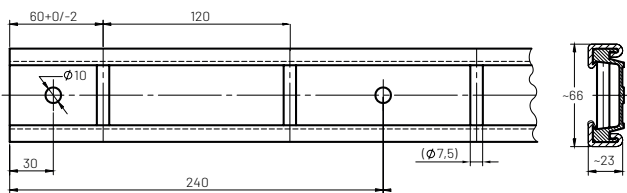

### Technical data

- > with rubber protection
- > width: 66 mm (incl. protective profile)
- > height: 23 mm (incl. protective profile)
- > rod diameter: 8 mm
- > hole pitch: Ø 10 mm, grid: 240 mm
- > pin: Ø 7.5 mm, grid: 120 mm
- > aluminium, untreated

Designation	Item number
Lashing 4710 rod 6,000 mm rubber	21471020-6000
Lashing 4710 rod 3,000 mm rubber	21471020-3000
Lashing 4710 rod 2,000 mm rubber	21471020-2000

## End cap for track with pins 4710



### Technical data

- > material: plastic
- > colour: black

Designation	Item number
Lashing 2106 protection wedge wide rod black	212106661540

## Aluminium track with pins 4720

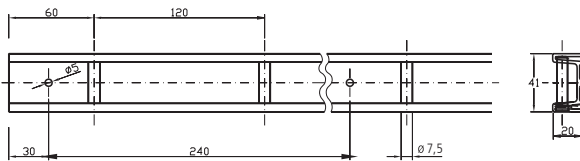

### Technical data

- > width: 41 mm
- > height: 20 mm
- > lengths: 6,000 mm / 3,000 mm / 2,000 mm
- > hole pitch: Ø 10 mm, grid: 240 mm
- > pin: Ø 7.5 mm, grid: 120 mm

Designation	Item number
Lashing 4720 rod 6,000 mm	21472020-6000
Lashing 4720 rod 3,000 mm	21472020-3000
Lashing 4720 rod 2,000 mm	21472020-2000

## End cap for track with pins 4720



grey colour based on RAL 7001

### Technical data

- > material: plastic
- > colour: grey

Designation	Item number
Lashing 2106 protection wedge narrow rod grey	212106462040

44

## Anchor combi lashing track 3009

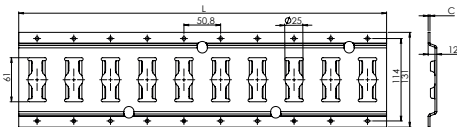
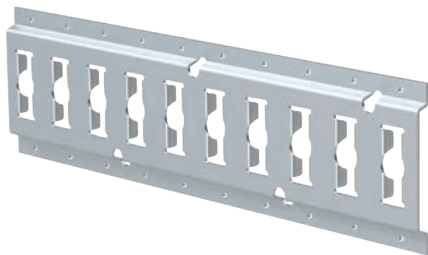

### Technical data

- > material: steel, galvanised / aluminium / stainless steel
- > length: 3,048 mm +/- 5
- > hole diameter: 25 mm
- > material thickness: 2.5 mm / 3.0 mm

Designation	Item number
Lashing 3009 2.5 mm galv. 3,048 mm	213009250012
Lashing 3009 3.0 mm galv. 3,048 mm	213009300012
Lashing 3009 3.0 mm aluminium 3,048 mm	213009300020
Lashing 3009 2.5 mm stainless steel 3,048 mm	213009250030

## Combi lashing track 3008

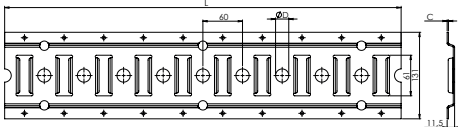
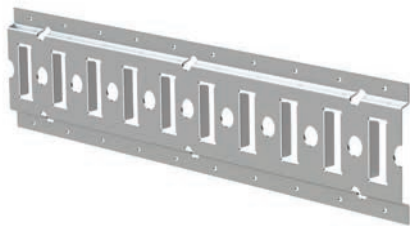

### Technical data

- > material: steel, galvanised / aluminium / stainless steel
- > length: 3,000 mm +/- 5
- > hole diameter: 20 mm / 25 mm
- > material thickness: 2.5 mm / 3.0 mm

Designation	Item number
Lashing 3008 2.5 mm galv. 3,000 mm 20 mm	213008252012
Lashing 3008 2.5 mm stainless steel 3,000 mm 20 mm	213008252030
Lashing 3008 2.5 mm galv. 3,000 mm 25 mm	213008252512
Lashing 3008 3.0 mm aluminium 3,000 mm 20 mm	213008302020

## Anchor combi lashing track, flat 3109

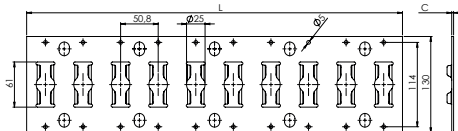
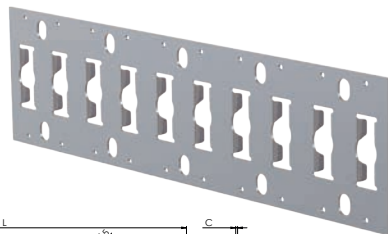

### Technical data

- > material: steel, galvanised / stainless steel
- > length: 3,048 mm +/- 5
- > hole diameter: 25 mm
- > material thickness: 2.5 mm

Designation	Item number
Lashing 3109 2.5 mm galv. 3,048 mm	213109250012
Lashing 3109 2.5 mm stainless steel 3,048 mm	213109250030

## Anchor combi lashing track 3108

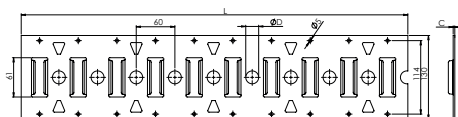
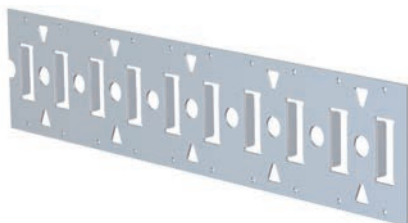

### Technical data

- > material: steel, galvanised / stainless steel
- > length: 3,000 mm +/- 5
- > hole diameter: 20 mm
- > material thickness: 2.5 mm

Designation	Item number
Lashing 3108 2.5 mm galv. 3,000 mm 20 mm	213108252012
Lashing 3108 2.5 mm stainless steel 3,000 mm 20 mm	213108252030

## End cap for combi and anchor combi lashing tracks



### Technical data

- > for combi and anchor combi lashing tracks Type 3008 / 3009

Designation	Item number
Lashing 2109 end cap long	212109951240

## Keyhole lashing track 1803, horizontal

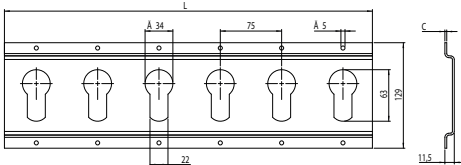
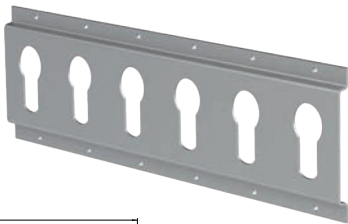

### Technical data

- > material: steel, galvanised
- > length: 3,000 mm +/- 5
- > material thickness: 2.3 mm

Designation	Item number
Lashing 1803 keyhole horizontal	211803200852

## Keyhole lashing track 1803, vertical

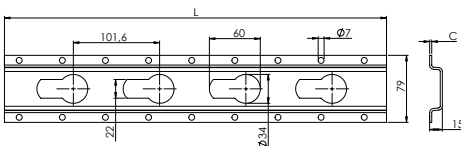
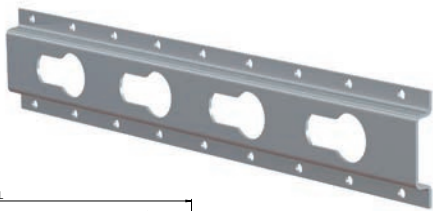

### Technical data

- > material: steel, galvanised
- > length: 3,000 mm +/- 5
- > material thickness: 2.5 mm

Designation	Item number
Lashing 1803 keyhole vertical	211803200152

## Round hole lashing track 1805

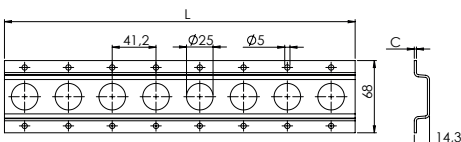
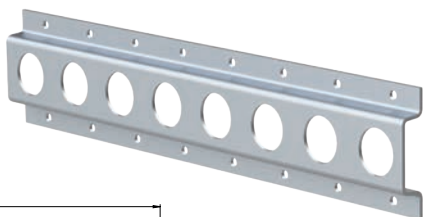

### Technical data

- > material: steel, galvanised
- > length: 3,048 mm +/- 3
- > hole diameter: 25 mm
- > material thickness: 2.0 mm

Designation	Item number
Lashing 1805 2.0 mm galv. 3,048 mm 25 mm	211805122512

## Round hole lashing track 1806 with cut-out

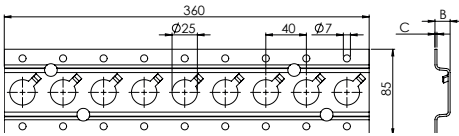
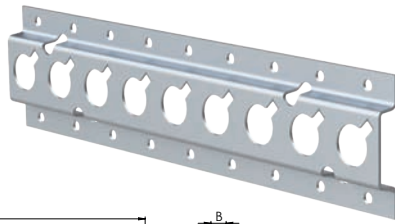

### Technical data

- > material: steel, galvanised
- > length: 3,000 mm +/- 5
- > hole diameter: 25 mm
- > material thickness: 2.5 mm

Designation	Item number
Lashing 1806 2.5 mm galv. 3,000 mm 25/12 mm	211806251212

## End cap for round hole lashing tracks



### Technical data

- > for round hole lashing track Type 1805 / 1806

Designation	Item number
Lashing 2106 end cap short	212106501240

## Round hole lashing track for the floor

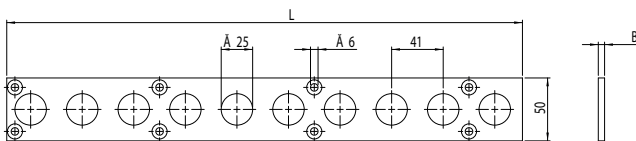

### Technical data

- > material: steel
- > length: 2,990 mm +/- 5
- > hole diameter: 25 mm
- > material thickness: 5.0 mm

Designation	Item number
Lashing 3004 5.0 mm galv. 2,990 mm 25 mm	213004502512

## Round hole lashing track for the floor

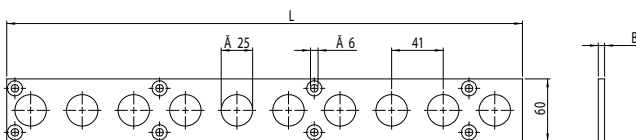

### Technical data

- > material: aluminium
- > length: 2,990 mm +/- 5
- > hole diameter: 25 mm
- > material thickness: 6.0 mm

Designation	Item number
Lashing 3004 6.0 mm aluminium 2,990 mm 25 mm	213004602520

## Single airline lashing track for double-deck loading

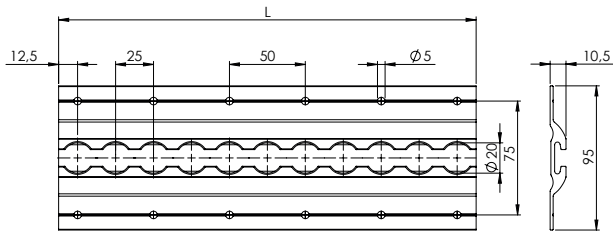
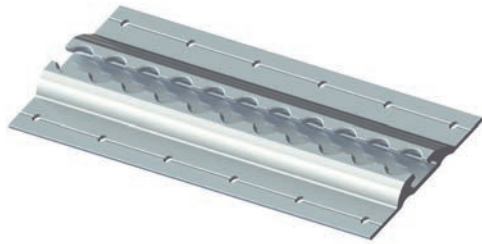

### Technical data

- > material: aluminium, untreated
- > incl. mounting holes
- > length: 1,975 mm +/- 5
- > hole diameter: 20 mm
- > hole pattern: 25.0 mm

Designation	Item number
Lashing 5001 air 1,975 mm bare	21500120-1975

## Tandem airline lashing track for double-deck loading

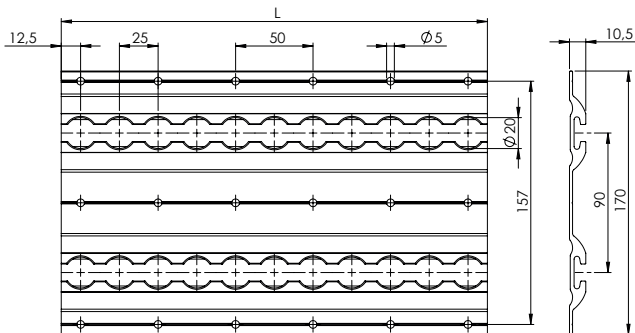

### Technical data

- > material: aluminium, untreated
- > incl. mounting holes
- > length: 1,975 mm +/- 5
- > hole diameter: 20 mm
- > hole pattern: 25.0 mm

Designation	Item number
Lashing 5021 air 1,975 mm tandem bare	21502120-1975



## Steel airline lashing track 5001

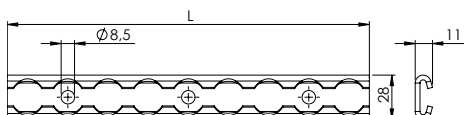

### Technical data

- > material: steel, galvanised
- > incl. mounting holes
- > length: 2,413 mm +/- 5
- > hole diameter: 20 mm
- > hole pattern: 25.4 mm
- > material thickness: 3.0 mm

Designation	Item number
Lashing 5001 air 2,413 mm +/- 5 steel	215001312012

## Anchor combi lashing track, vertical

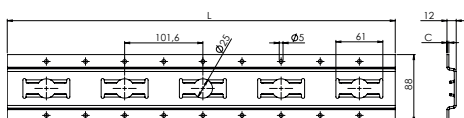
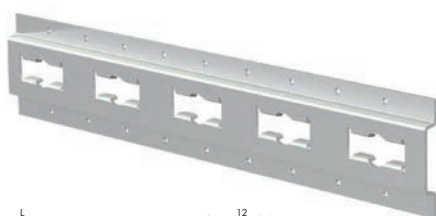

### Technical data

- > material: steel, galvanised
- > length: 2,438 mm +/- 5
- > hole diameter: 25 mm
- > material thickness: 2.5 mm

Designation	Item number
Lashing 2010 2.5 mm galv. 2,438 mm +/- 5	212010250812

## End fitting 821 for anchor combi lashing tracks



### Technical data

- > LC (lashing capacity): 1,000 daN
- > ring diameter (inner): 33 mm

Designation	Item number
End fitting 821 f anchor combi track	140000082100

## End fitting 822 for anchor combi lashing tracks



### Technical data

- > LC (lashing capacity): 1,000 daN
- > ring diameter (inner): 34 mm

Designation	Item number
End fitting 822 for anchor combi MBL 2000 daN	140000082200

## WTR 1500-826 Ratchet lashing strap



### Technical data

- > two-part - SE 1.0 m + LE 4.0 m
- > according to EN 12195-2
- > LC 750 daN with straight tension
- > STF 210 daN
- > with end fitting **826** (for combi and anchor combi lashing tracks)
- > strap: 50 mm, green

Designation	Item number
WTR 1500-826 1.0 + 4.0 m green	1504273
WTR 1500-826 0.5 + 4.5 m green	1504252

## WTR 1500-828 Ratchet lashing strap



### Technical data

- > two-part - SE 0.5 m + LE 4.5 m
- > according to EN 12195-2
- > LC 750 daN with straight tension
- > STF 210 daN
- > with end fitting **828** (for keyhole lashing tracks)
- > strap: 50 mm, green

Designation	Item number
WTR 1500-828 0.5 + 4.5 green	1504370

## WTK 1000-826 cam buckle strap



### Technical data

- > two-part - SE 1.0 m + LE 4.0 m
- > according to EN 12195-2
- > LC 500 daN with straight tension
- > with end fitting **826** (for combi and anchor combi lashing tracks)
- > strap: 50 mm, green

Designation	Item number
WTK 1000-826 1.0 + 4.0 m green	1503826

## WTK 1000-828 cam buckle strap



### Technical data

- > two-part – SE 1.5 m + LE 2.5 m
- > according to EN 12195-2
- > LC 500 daN with straight tension
- > with end fitting **828** (for keyhole lashing tracks)
- > strap: 50 mm, blue

Designation	Item number
WTK 1000-828 1.5 + 2.5 blue	1501346



## WIS Aluminium shoring beam COMBI-BEAM 1858



### Technical data

The COMBI-BEAM 1858 + 18z59 is a WISTRA development with a particular focus on user-friendliness and gentle use in pressure-sensitive vehicle areas.

- > range of application 2,450 – 2,500 mm
- > support tube made of aluminium
- > 1858 version equipped with black PVC hose
- > 1859 without PVC hose
- > with end piece 1858 for combi or anchor combi lashing tracks
- > with WIS product sticker or with customer-specific product sticker



Designation	Item number
Shoring beam 1858 2430 PVC WIS sticker	221858001-2450
Shoring beam 1858 2430 PVC div sticker	221858999-2450



Designation	Item number
Shoring beam 1859 2450 WIS sticker	221859001-2450
Shoring beam 1859 2450 div sticker	221859999-2450

Advantages	for the user	for the means of transport / the cargo	compared to similar products
In conjunction with non-slip materials, cargo with a weight of up to 2,000 kg can be secured in the direction of travel using one Combi-Beam	✓	✓	✓
Easy telescoping as standard up to 70 mm	✓		✓
No protruding operating controls over its entire range	✓	✓	✓
Silent design with plastic centring piece	✓		✓
Version 1858: Support tube with PVC coating for a pleasant user feel, even at cool outside temperatures, and as protection for the cargo	✓	✓	✓
The combination pins on both sides snap into the combi lashing track	✓	✓	✓
The combination pins are gentle on the material inside the lashing track	✓	✓	✓
When the Combi-Beam is inserted by the user, no simultaneous pressure is required	✓	✓	✓
The combination pins are prevented from slipping out by a locking mechanism activated by applying pressure to the side panel	✓	✓	✓
Thanks to the locking mechanism in the combi lashing track, the system does not damage the transport vehicle	✓	✓	✓
High-quality product identification glued to the telescope	✓		✓

## Shoring beam end pin versions

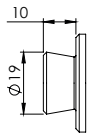

**Version: 09**  
19 mm pin

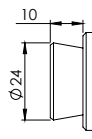

**Version: 24**  
24 mm pin

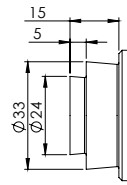

**Version: 43**  
24/33 mm combination pin

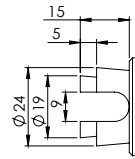

**Version: 45**  
19/24 mm pin for rod rail

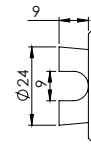

**Version: 49**  
24 mm pin for rod rail

## Steel shoring beam



### Technical data

- > support tube diameter 42 mm
- > end pin version 09 / 24 / 43 / 44 / 45 / 49
- > blocking force BC 500 daN with uniform surface load
- > for vehicle interior dimensions 2,440 – 2,520 mm

Designation	Item number
Shoring beam 1817 steel 09	221817000912
Shoring beam 1817 steel 24	221817002412
Shoring beam 1817 steel 43	221817004312
Shoring beam 1817 steel 44	221817004412
Shoring beam 1817 steel 45	221817004512
Shoring beam 1817 steel 49	221817004912

## Steel shoring beam



### Technical data

- > with PVC coating in blue
- > support tube diameter 42 mm
- > end pin version 09 / 24 / 43 / 44 / 45 / 49
- > blocking force BC 500 daN with uniform surface load
- > for vehicle interior dimensions 2,440 – 2,520 mm

Designation	Item number
Shoring beam 1817 steel 09 Ü	221817000912Ü
Shoring beam 1817 steel 24 Ü	221817002412Ü
Shoring beam 1817 steel 43 Ü	221817004312Ü
Shoring beam 1817 steel 44 Ü	221817004412Ü
Shoring beam 1817 steel 45 Ü	221817004512Ü
Shoring beam 1817 steel 49 Ü	221817004912Ü

## Cargo securing for box trucks

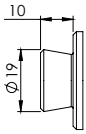

**Version: 09**  
19 mm pin

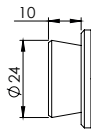

**Version: 24**  
24 mm pin

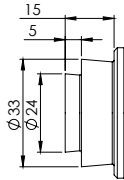

**Version: 43**  
24/33 mm combination pin

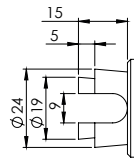

**Version: 45**  
19/24 mm pin for rod rail

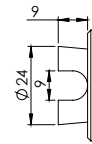

**Version: 49**  
24 mm pin for rod rail

## Aluminium shoring beam

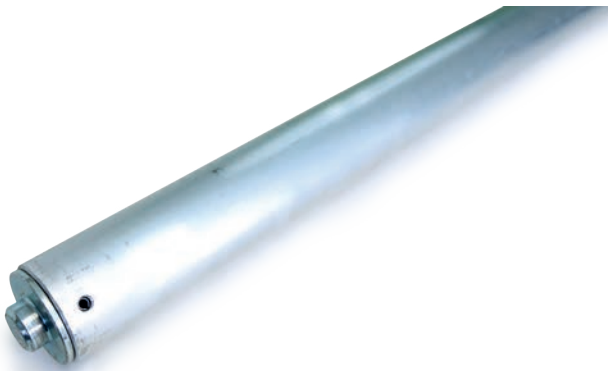

### Technical data

- > support tube diameter 42 mm
- > end pin version 09 / 24 / 43 / 44 / 45 / 49
- > blocking force BC 400 daN with uniform surface load
- > for vehicle interior dimensions 2,440 – 2,520 mm

Designation	Item number
Shoring beam 1817 aluminium 09	221817000920
Shoring beam 1817 aluminium 24	221817002420
Shoring beam 1817 aluminium 43	221817004320
Shoring beam 1817 aluminium 44	221817004420
Shoring beam 1817 aluminium 45	221817004520
Shoring beam 1817 aluminium 49	221817004920

## Aluminium shoring beam



### Technical data

- > with PVC coating in blue
- > support tube diameter 42 mm
- > end pin version 09 / 24 / 43 / 44 / 45 / 49
- > blocking force BC 400 daN with uniform surface load
- > for vehicle interior dimensions 2,440 – 2,520 mm

Designation	Item number
Shoring beam 1817 aluminium 09 Ü	221817000920Ü
Shoring beam 1817 aluminium 24 Ü	221817002420Ü
Shoring beam 1817 aluminium 43 Ü	221817004320Ü
Shoring beam 1817 aluminium 44 Ü	221817004420Ü
Shoring beam 1817 aluminium 45 Ü	221817004520Ü
Shoring beam 1817 aluminium 49 Ü	221817004920Ü

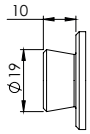

**Version: 09**  
19 mm pin

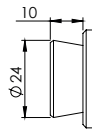

**Version: 24**  
24 mm pin

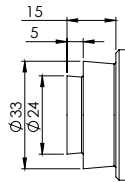

**Version: 43**  
24/33 mm combination pin

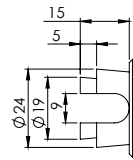

**Version: 45**  
19/24 mm pin for rod rail

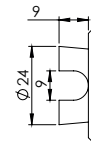

**Version: 49**  
24 mm pin for rod rail

## Steel shoring beam, adjustable



### Technical data

- > support tube diameter: 42 mm
- > end pin version 09 / 24 / 43 / 44 / 45 / 49
- > blocking force BC 500 daN with uniform surface load
- > possible application range: 2,235 – 2,685 mm

Designation	Item number
Shoring beam 1811 steel 09	221811000912
Shoring beam 1811 steel 24	221811002412
Shoring beam 1811 steel 43	221811004312
Shoring beam 1811 steel 44	221811004412
Shoring beam 1811 steel 45	221811004512
Shoring beam 1811 steel 49	221811004912

## Steel shoring beam, adjustable



### Technical data

- > with PVC coating in blue
- > support tube diameter: 42 mm
- > end pin version 09 / 24 / 43 / 44 / 45 / 49
- > blocking force BC 500 daN with uniform surface load
- > possible application range: 2,235 – 2,685 mm

Designation	Item number
Shoring beam 1811 steel 09 Ü	221811000912Ü
Shoring beam 1811 steel 24 Ü	221811002412Ü
Shoring beam 1811 steel 43 Ü	221811004312Ü
Shoring beam 1811 steel 44 Ü	221811004412Ü
Shoring beam 1811 steel 45 Ü	221811004512Ü
Shoring beam 1811 steel 49 Ü	221811004912Ü

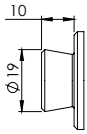

**Version: 09**  
19 mm pin

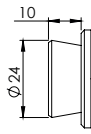

**Version: 24**  
24 mm pin

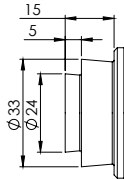

**Version: 43**  
24/33 mm combination pin

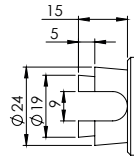

**Version: 45**  
19/24 mm pin for rod rail

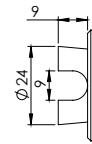

**Version: 49**  
24 mm pin for rod rail

## Aluminium shoring beam, adjustable



### Technical data

- > support tube diameter: 42 mm
- > end pin version 09 / 24 / 43 / 44 / 45 / 49
- > blocking force BC 400 daN with uniform surface load
- > possible application range: 2,235 – 2,685 mm

Designation	Item number
Shoring beam 1808 aluminium 09	221808000920
Shoring beam 1808 aluminium 24	221808002420
Shoring beam 1808 aluminium 43	221808004320
Shoring beam 1808 aluminium 44	221808004420
Shoring beam 1808 aluminium 45	221808004520
Shoring beam 1808 aluminium 49	221808004920

## Aluminium shoring beam, adjustable



### Technical data

- > with PVC coating in blue
- > support tube diameter: 42 mm
- > end pin version 09 / 24 / 43 / 44 / 45 / 49
- > blocking force BC 400 daN with uniform surface load
- > possible application range: 2,235 – 2,685 mm

Designation	Item number
Shoring beam 1808 aluminium 09 Ü	221808000920Ü
Shoring beam 1808 aluminium 24 Ü	221808002420Ü
Shoring beam 1808 aluminium 43 Ü	221808004320Ü
Shoring beam 1808 aluminium 44 Ü	221808004420Ü
Shoring beam 1808 aluminium 45 Ü	221808004520Ü
Shoring beam 1808 aluminium 49 Ü	221808004920Ü



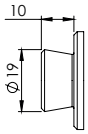

**Version: 09**  
19 mm pin

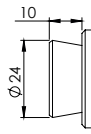

**Version: 24**  
24 mm pin

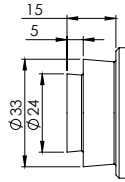

**Version: 43**  
24/33 mm combination pin

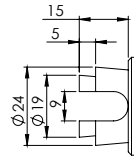

**Version: 45**  
19/24 mm pin for rod rail

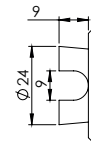

**Version: 49**  
24 mm pin for rod rail

## "Power" – Aluminium shoring beam

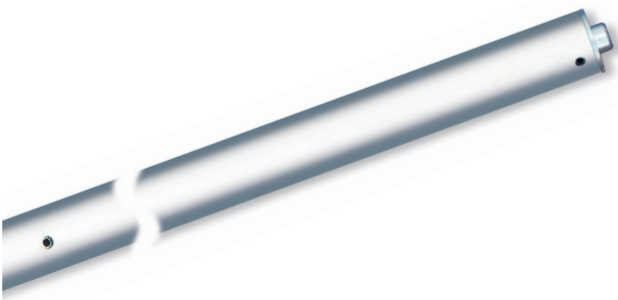

### Technical data

- > support tube diameter: 50 mm
- > end pin version 09
- > blocking force BC 700 daN with uniform surface load
- > for vehicle interior dimensions 2,400 – 2,480 mm

Designation	Item number
Shoring beam 1850 aluminium 09 2,440 mm	221850150920

## "Power" – Aluminium shoring beam

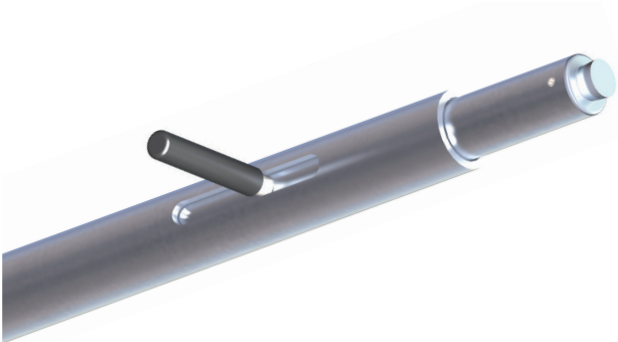

### Technical data

- > "ergo" version – the additional handle facilitates the use of the shoring beam
- > support tube diameter: 50 mm
- > end pin version 09
- > blocking force BC 700 daN with uniform surface load
- > for vehicle interior dimensions 2,400 – 2,480 mm

Designation	Item number
Shoring beam 1854 aluminium 2,430 mm	221854010920-2430

## Cargo securing for box trucks

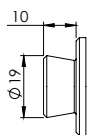

**Version: 09**  
19 mm pin

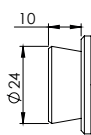

**Version: 24**  
24 mm pin

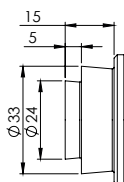

**Version: 43**  
24/33 mm combination pin

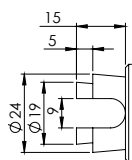

**Version: 45**  
19/24 mm pin for rod rail

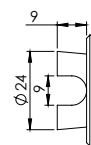

**Version: 49**  
24 mm pin for rod rail

## Square steel shoring beam

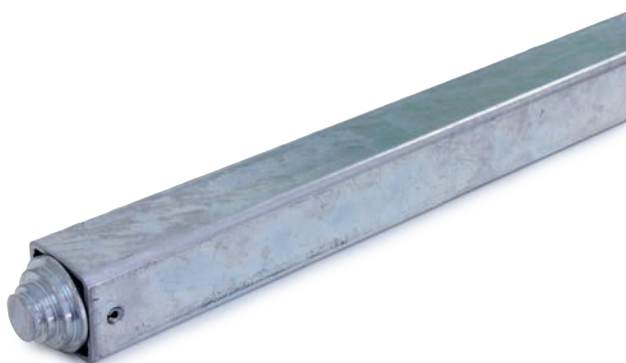

### Technical data

- > support tube: 40 x 40 mm
- > end pin version 44
- > blocking force BC 500 daN with uniform surface load
- > for vehicle interior dimensions 2,440 - 2,520 mm

Designation	Item number
Shoring beam 1827 steel 44	221827004412

## Square steel shoring beam, adjustable

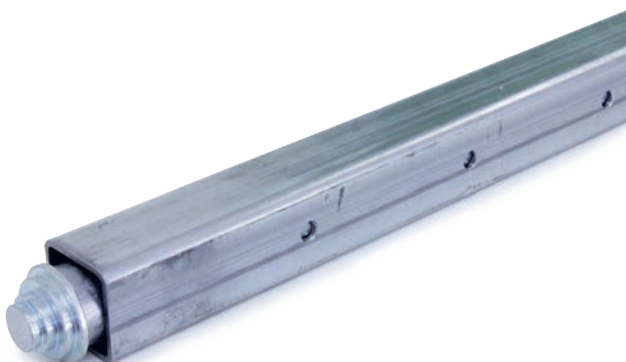

### Technical data

- > support tube: 40 x 40 mm
- > end pin version 44
- > blocking force BC 500 daN with uniform surface load
- > possible application range: 2,235 - 2,685 mm

Designation	Item number
Shoring beam 1812 steel 44	221812004412

## Aluminium cargo bar 1842, 1843, 1845



### Technical data

- > support tube diameter: 42 mm
- > operating element: lever with rack
- > equipped with non-slip rubber feet on both sides
- > with spring system

Designation	Item number
Cargo bar 1842 2,100 – 2,470 mm	221842010020TW
Cargo bar 1843 2,350 – 2,720 mm	221843010020TW
Cargo bar 1844 2,500 – 2,870 mm	221844010020TW
Cargo bar 1845 2,650 – 3,020 mm	221845010020TW

## Aluminium cargo bar 1867



### Technical data

- > support tube diameter: 38 mm
- > operating element: lever with rack
- > equipped with non-slip rubber feet on both sides
- > with spring system

Designation	Item number
1867 2,260 – 2,630 mm	221867010020TW

## Steel cargo bar 1840



### Technical data

- > support tube: 35 x 35 mm
- > operating element: lever with hole grid in telescopic tube
- > equipped with non-slip rubber feet on both sides
- > with spring system

Designation	Item number
Cargo bar 1840 1,900 – 2,800 mm blue feet	221840000012

## Aluminium loading decking beam



### Technical data

- > with steel end pieces which can be pulled out on both sides for fixing in a combi or anchor combi lashing track
- > end pieces equipped with innovative "Easy-Unlock button"
- > application range: 2,430 - 2,650 mm

Designation	Item number
Loading beam 1835 2,430 - 2,650 mm	22183500-2320

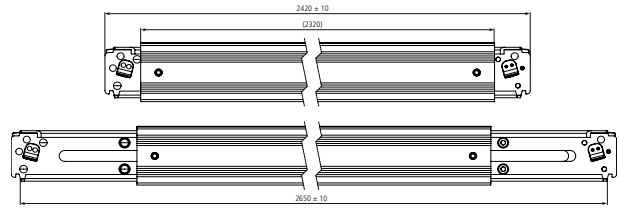
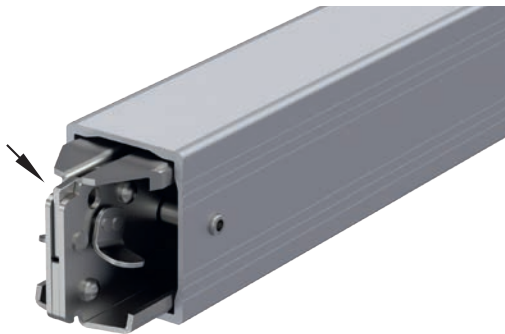

Locked state in the lashing track

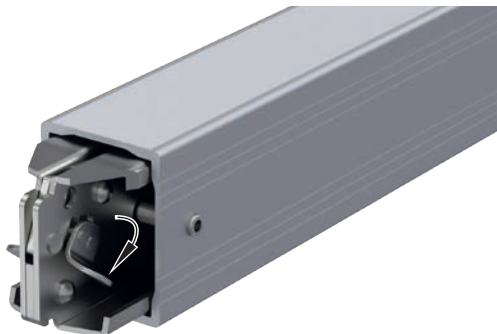

Simple unlocking by slightly pressing the "Easy-Unlock" button

### Loading beam suitable for these tracks

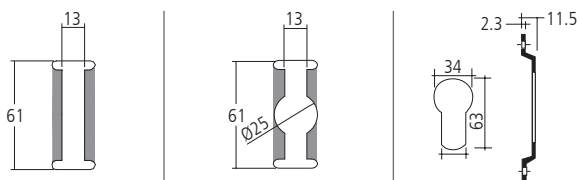

## Aluminium loading decking beam



### Technical data

- > with double-sided extendible steel end pieces for fixing in a Talfix perforated sheet panel
- > application range: 2,460 – 2,700 mm

Designation	Item number
Loading beam 1839 AT/AT-2350 Talfix	22183940-2350

Loading beam suitable for these perforated sheets

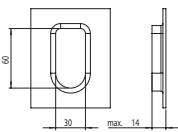

## Aluminium sliding decking beam 7007, 7008



### Technical data

- > version 7007: with double-sided extendible aluminium end pieces for fixing in an aluminium guide rail (50 mm rail width)
- > version 7008: with double-sided extendible aluminium end pieces for fixing in an aluminium guide rail (68 mm rail width)
- > application range: 2,450 – 2,530 mm

Designation	Item number
Articulated loading beam 7007 2,450 – 2,530 mm	227007000020
Articulated loading beam 7008 2,450 – 2,530 mm	227008000020

Loading beam suitable for these tracks



Single aluminium guiding track 7002



Tandem aluminium guiding track 7002

## Aluminium sliding decking beam 5003

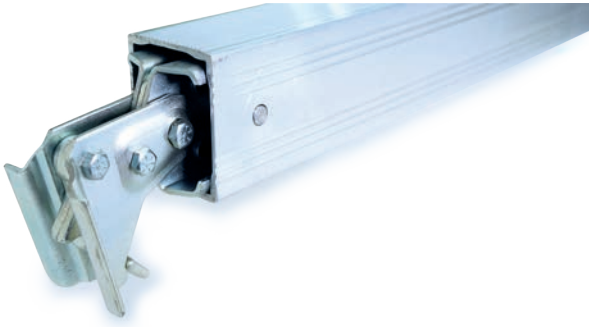

### Technical data

- > with double-sided extendible steel end pieces for fixing in a steel guiding track (50 mm rail width)
- > application range: 2,450 – 2,530 mm

Designation	Item number
Articulated loading beam 5003 2,450 – 2,530 mm	225003000012

Loading beam suitable for these tracks



Single steel  
guiding track  
7004

## Aluminium sliding decking beam 7105



### Technical data

- > with double-sided extendible aluminium end pieces for locking in an airline rail made of aluminium
- > application range: 2,370 – 2,600 mm

Designation	Item number
Articulated loading beam 7105 2,250 mm	227105000120

Loading beam suitable for airline guide lashing tracks

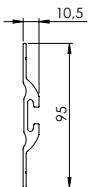

Single airline  
lashing track  
5001

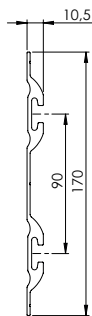

Tandem airline  
lashing track  
5021

## Garment rail K7 with plastic end piece



### Technical data

- > for fixing in a full or half-flanged keyhole plate
- > application range: 2,420 – 2,500 mm
- > support tube length: 2,370 mm (chrome-plated)
- > spring function: pulling
- > equipped with two Velcro straps for securing the throw bar

Designation	Item number
Clothes rail K7-1	267191237017

## Garment rail U71 with steel end piece



### Technical data

- > for locking in a combi or anchor combi rail
- > application range: 2,420 – 2,500 mm
- > support tube length: 2,370 mm (chrome-plated)
- > without spring function
- > equipped with two Velcro straps for securing the throw bar

Designation	Item number
Clothes rail U71	267382137017

## Garment rail S7 with steel end piece



### Technical data

- > for fixing in a keyhole lashing track without flanging
- > application range: 2,420 – 2,500 mm
- > support tube length: 2,370 mm (chrome-plated)
- > without spring function
- > equipped with two Velcro straps for securing the throw bar

Designation	Item number
Clothes rail S7 without spring	267390337017

## Door gears

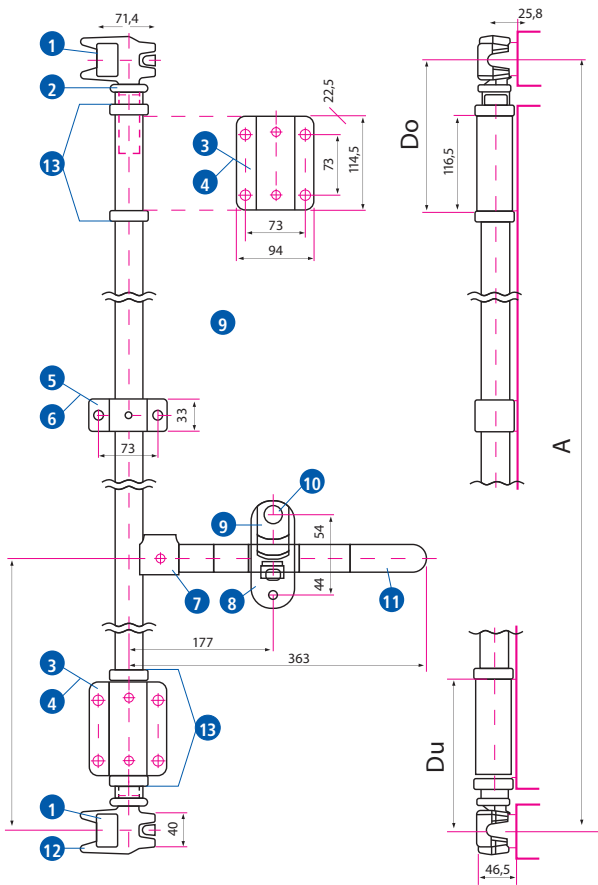

- > bolt, hot-dip galvanised (9)

Designation	Item number
Seal pin, hot-dip galvanised KT	34012.05

- > rivet, galvanised (10)

Designation	Item number
Rivet, zinc-plated Flat head KT	33089.03

- > lever, hot-dip galvanised (11)

Designation	Item number
Lever, hot-dip galvanised KT	34090.05

- > cam piece, untreated (12)

Designation	Item number
Cam KT	34201.01

- > anti-rack ring, untreated (13)

Designation	Item number
Anti-rack ring, s/c KT	33901.01

### Technical data

- > complete "Powerbrace 3491" kit
- > without tube

Designation	Item number
DOOR GEAR kit catalogue	3491000

- > bracket, untreated (1)

Designation	Item number
Keeper Quad Finger KT	34237.01

- > cam piece, untreated (2)

Designation	Item number
Cam KT	34202.01

- > rod guide, hot-dip galvanised (3)

Designation	Item number
Cam guide, hot-dip galvanised KT	36008.05

- > bushing for rod guide, plastic (4)

Designation	Item number
Cam guide bearing KT	36009.01

- > rod bracket, hot-dip galvanised (5)

Designation	Item number
Rod guide, hot-dip galvanised KT	36010.05

- > bushing for rod bracket, plastic (6)

Designation	Item number
Rod guide bearing KT	36011.01

- > lever joint, untreated (7)

Designation	Item number
Lever mount, s/c KT	33071.01

- > lever bracket, hot-dip galvanised (8)

Designation	Item number
Seal plate, hot-dip galvanised KT	34011.05



---

## The WISTRA Sprinter on tour



Top seller

## Airline lashing track 5503

---

More on page 68



**Cargo securing for  
transporters and trailers**

## Airline lashing tracks



The WISTRA airline lashing tracks and accessories are subject to constant material and quality checks.

With the continuously growing number of different designs, we offer our customers airline lashing tracks for the different areas in the transporter, trailer and luggage area.

An extensive offer of lashing straps, Safeguard cargo securing nets, locking and cargo bar systems, clothes transport rails as well as fastening systems and various end caps round off the range.

The WISTRA airline lashing program includes non-coated standard versions.

On request, we also offer special solutions and designs with holes or surface finishes such as powder or anodized coatings.

We deliberately do without impressive strength values. In our in-house test stand, the LC values for single and double fittings with the fastenings specified by us for the respective versions were determined.

Please note that the type of connection (screws, rivets, adhesives, etc.) and the strength of the substrate (spars, beams, sheets, etc.) are decisive when installing airline lashing tracks.

A further decisive factor is which lashing strap is used with which end fitting (single, double or quattro) and at which angle.

Our sales team will gladly assist you with your selection.

### WISTRA Info

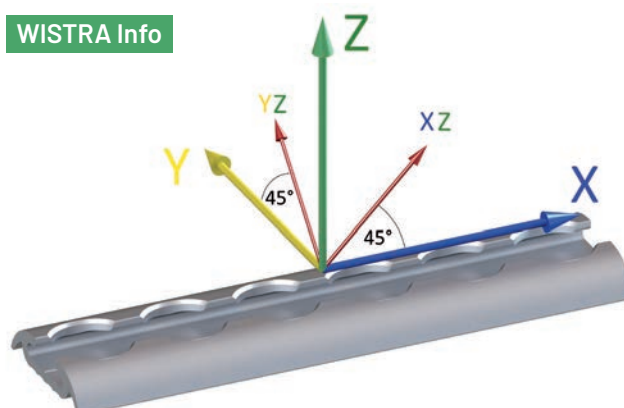

## Airline lashing track 5503

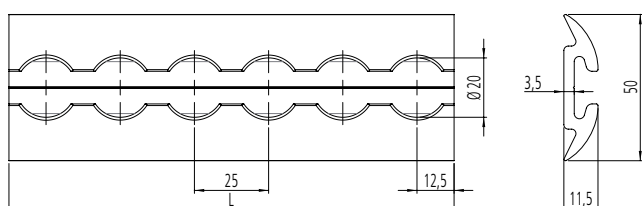
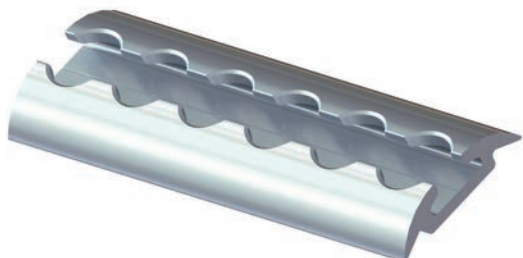

### Technical data

- > semi-circular design
- > track width: 50 mm
- > hole diameter: 20 mm
- > hole pattern: 25 mm
- > length: 6,000 mm +5/-0 / 3,000 mm +1/-5 / 2,000 mm +1/-5
- > material: aluminium, untreated

Designation	Item number
Lashing 5503 air 6,000 mm bare	21550320-6000
Lashing 5503 air 3,000 mm bare	21550320-3000
Lashing 5503 air 2,000 mm bare	21550320-2000

### LC strength

WIS end fitting	382	380
Z 90°	500 daN	1,000 daN
X-Z 45°	500 daN	1,000 daN
Y-Z 45°	400 daN	900 daN

LC strength for mounting: every 75 mm with a countersunk screw M6 DIN 7991 10.9

## End cap in click version



### Technical data

- > for airline track Type 5503
- > colour: black

Designation	Item number
Lashing 5106 air protection semi-black click	215106001540

## Airline lashing track 5513

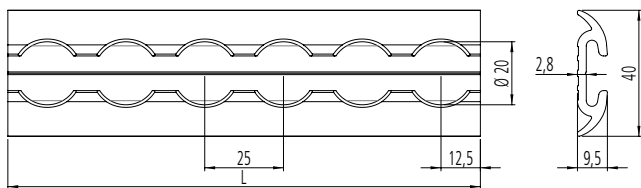

### Technical data

- > semi-circular design
- > track width: 40 mm (slim version)
- > hole diameter: 20 mm
- > hole pattern: 25 mm
- > length: 3,000 mm +1/-5 / 2,000 mm +1/-5 / 1,000 mm +1/- 5
- > material: aluminium, untreated

Designation	Item number
Lashing 5513 Air 3,000 mm bare slim	21551320-3000
Lashing 5513 Air 2,000 mm bare slim	21551320-2000
Lashing 5513 air 1,000 mm bare slim	21551320-1000

### LC strength

WIS end fitting	382	380
Z 90°	500 daN	600 daN
X-Z 45°	500 daN	500 daN
Y-Z 45°	350 daN	400 daN

LC-strength for mounting: every 75 mm with a countersunk screw M5 DIN 7991 10.9

## End cap in click version



### Technical data

- > for airline track Type 5513
- > colour: black

Designation	Item number
Lashing 5113 air protection semi-circular slim click	215113001540

## Airline lashing track 5504

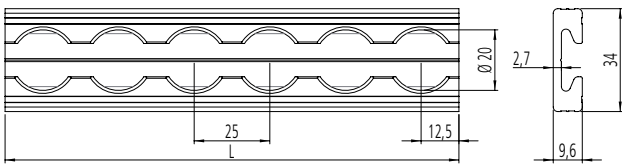

### Technical data

- > angular design
- > track width: 34 mm
- > hole diameter: 20 mm
- > hole pattern: 25 mm
- > length: 6,000 mm +5/-0 / 3,000 mm +5/-0 / 2,000 mm +5/-0
- > material: aluminium, untreated

Designation	Item number
Lashing 5504 air 6,000 mm bare	21550420-6000
Lashing 5504 air 3,000 mm bare	21550420-3000
Lashing 5504 air 2,000 mm bare	21550420-2000

### LC strength

WIS end fitting	382	380
Z 90°	500 daN	500 daN
X-Z 45°	500 daN	500 daN
Y-Z 45°	400 daN	400 daN

LC-strength for mounting: every 75 mm with a countersunk screw M5 DIN 7991 10.9

## End cap in click version



### Technical data

- > for airline track Type 5504
- > colour: black

Designation	Item number
Lashing 5103 air protection wedge square black	215103001540

## Airline lashing track 5514

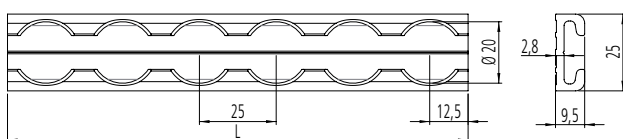

### Technical data

- > angular design
- > track width: 25 mm (slim version)
- > hole diameter: 20 mm
- > hole pattern: 25 mm
- > length: 3,000 mm +1/-5 / 2,000 mm +1/-5 / 1,000 mm +1/-5
- > material: aluminium, untreated

Designation	Item number
Lashing 5514 air 3,000 mm bare slim	21551420-3000
Lashing 5514 air 2,000 mm bare slim	21551420-2000
Lashing 5514 air 1,000 mm bare slim	21551420-1000

### LC strength

WIS end fitting	382	380
Z 90°	450 daN	450 daN
X-Z 45°	350 daN	450 daN
Y-Z 45°	250 daN	300 daN

LC-strength for mounting: every 75 mm with a countersunk screw M5 DIN 7991 10.9

## End cap in click version



### Technical data

- > for airline track Type 5514
- > colour: black

Designation	Item number
Lashing 5114 air protection wedge slim click	215114001540

## Airline lashing track 5508, pre-assembled



blue colour based on RAL 5002

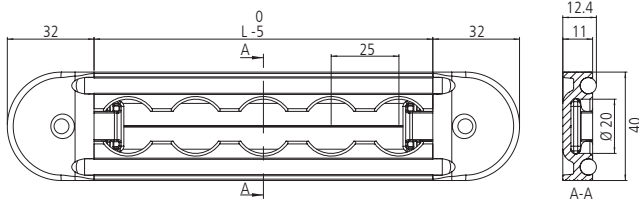

### Technical data

- > track width: 40 mm
- > hole diameter: 20 mm
- > hole pattern: 25 mm
- > length of lashing track: 3,000 mm +1/-5 / 2,000 mm +1/-5 / 1,000 mm +1/-5
- > length incl. end caps: 3,064 mm +1/-5 / 2,064 mm +1/-5 / 1,064 mm +1/-5
- > material: aluminium, untreated

### angular design black with integrated rubber protection and 2 end caps

Designation	Item number
Lashing 5508 air set 3,000 mm	21550877-3000
Lashing 5508 air set 2,000 mm	21550877-2000
Lashing 5508 air set 1,000 mm	21550877-1000

### angular design blue with integrated silicone protection and 2 end caps

Bezeichnung	Artikelnummer
Lashing 5508 air set 3,000 mm	21550878-3000
Lashing 5508 air set 2,000 mm	21550878-2000
Lashing 5508 air set 1,000 mm	21550878-1000

## Airline lashing track 5508

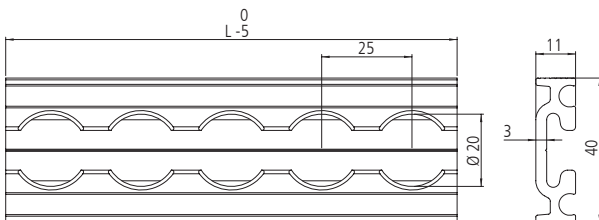
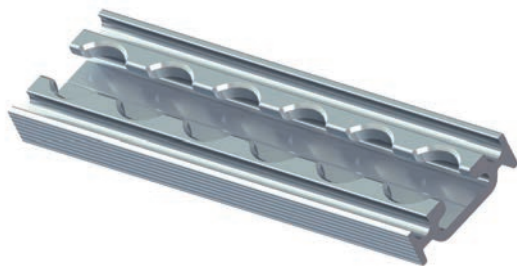

### Technical data

- > design without rubber protection and without end caps
- > track width: 40 mm
- > hole diameter: 20 mm
- > hole pattern: 25 mm
- > length of lashing track: 3,000 mm +1/-5
- > material: aluminium, untreated

Designation	Item number
Lashing 5508 air 3,000 mm bare without rubber	21550820-3000

### LC strength

WIS end fitting	382	380
Z 90°	500 daN	1,000 daN
X-Z 45°	500 daN	1,000 daN
Y-Z 45°	400 daN	900 daN

LC strength for mounting: every 75 mm with a countersunk screw M6 DIN 7991 10.9



## Band for airline track Type 5508



blue colour based on RAL 5002

### Technical data

- > rubber band black: 50 metres on a roll

Designation	Item number
Lashing 5508 rubber metre goods (50 m rolls)	21550800-50000

- > silicone band blue: 50 metres on a roll

Designation	Item number
Lashing 5508 silicone metre goods (100 m rolls)	21550801-100000

## End cap in click version



blue colour based on RAL 5002

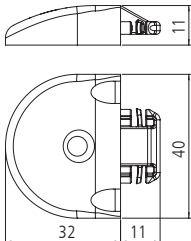

### Technical data

- > for airline track Type 5508

#### Black plastic end cap

Designation	Item number
End cap 5104 for airline lashing track 5508	215104001540

#### Blue plastic end cap

Designation	Item number
End cap 5104 for airline lashing track 5508	215104001340

## Custom made track



### Configure your airline lashing track yourself!

- 1 You determine the type.
- 2 You decide whether aluminium is untreated, anodised or powder-coated.
- 3 You determine the length.

- 4 You determine the number and design of the mounting hole.
- 5 You determine possible radii at the corners.

**We implement your wishes. Contact us!**

## Airline lashing track 5507

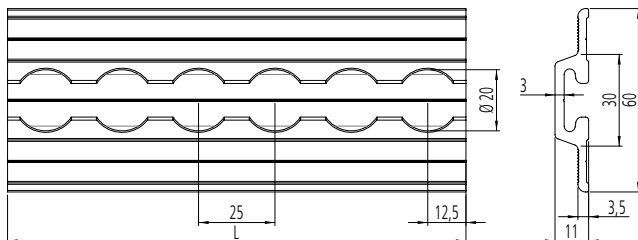
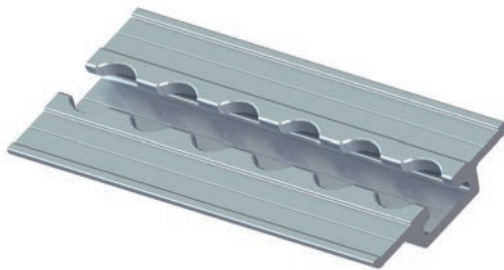

### Technical data

- > with top wing for integration in the cargo area floor
- > track width: 60 mm
- > hole diameter: 20 mm
- > hole pattern: 25 mm
- > length: 3,000 mm +1/-5
- > material: aluminium, untreated

Designation	Item number
Lashing 5507 air 3,000 mm bare	21550720-3000

### LC strength

WIS end fitting	382	380
Z 90°	500 daN	1,000 daN
X-Z 45°	500 daN	1,000 daN
Y-Z 45°	400 daN	900 daN

LC strength for mounting: every 75 mm with a countersunk screw M6 DIN 7991 10.9

## Airline lashing track 5501

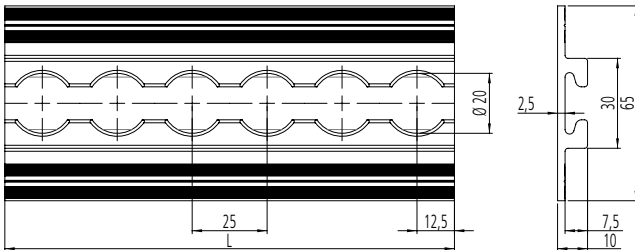
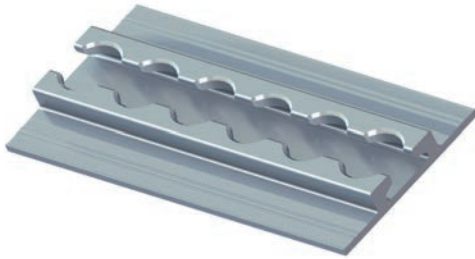

### Technical data

- > with bottom wing for integration in the cargo area floor
- > track width: 65 mm
- > track height: 10 mm
- > hole diameter: 20 mm
- > hole pattern: 25 mm
- > length: 3,000 mm +1/-5
- > material: aluminium, untreated

Designation	Item number
Lashing 5501 air 3,000 mm bare	21550120-3000

### LC strength

WIS end fitting	382	380
Z 90°	500 daN	500 daN
X-Z 45°	500 daN	500 daN
Y-Z 45°	400 daN	400 daN

Lashing capacity for attachment: every 75 mm oppositely with a countersunk screw M6 DIN 7380 8.8

## Airline lashing track 5510

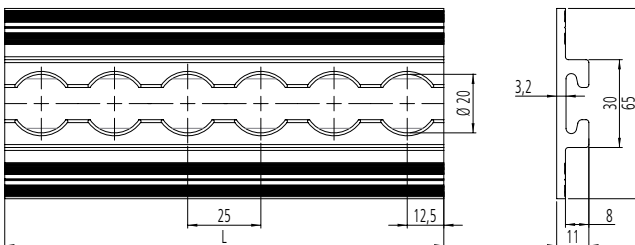
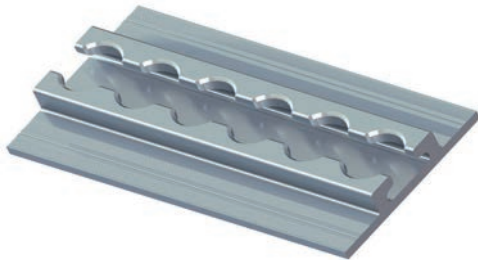

### Technical data

- > with bottom wing for integration in the cargo area floor
- > track width: 65 mm
- > track height: 11 mm
- > hole diameter: 20 mm
- > hole pattern: 25 mm
- > length: 3,000 mm +1/-5
- > material: aluminium, untreated

Designation	Item number
Lashing 5510 air 3,000 mm bare	21551020-3000

### LC strength

WIS end fitting	382	380
Z 90°	500 daN	1,000 daN
X-Z 45°	500 daN	1,000 daN
Y-Z 45°	400 daN	900 daN

Lashing capacity for attachment: every 75 mm oppositely with a countersunk screw M6 DIN 7380 8.8

## Airline lashing track 5506

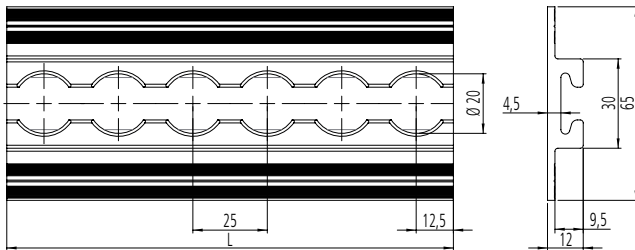
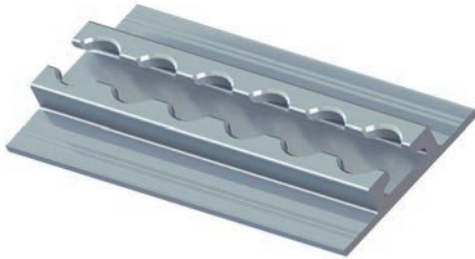

### Technical data

- > with bottom wing for integration in the cargo area floor
- > track width: 65 mm
- > track height: 12 mm
- > hole diameter: 20 mm
- > hole pattern: 25 mm
- > length: 6,000 mm +1/-5 / 3,000 mm +1/-5
- > material: aluminium, untreated

Designation	Item number
Lashing 5506 air 6,000 mm bare 12 mm	21550620-6000
Lashing 5506 air 3,000 mm bare 12 mm	21550620-3000

### LC strength

WIS end fitting	382	380
Z 90°	500 daN	1,000 daN
X-Z 45°	500 daN	1,000 daN
Y-Z 45°	400 daN	900 daN

Lashing capacity for attachment: every 75 mm oppositely with a countersunk screw M6 DIN 7380 8.8

## End cap in click version



### Technical data

- > for airline track Type 5506
- > colour: black

Designation	Item number
Lashing 5105 air protection wedge black	215105001540

## Airline lashing track 5502

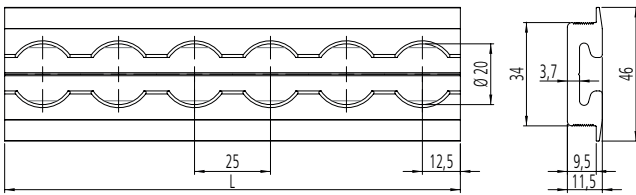

### Technical data

- > with top wing for integration in the cargo area floor
- > track width: 46 mm
- > hole diameter: 20 mm
- > hole pattern: 25 mm
- > length: 6,000 mm +1/-5 / 3,000 mm +1/-5 / 2,000 mm +1/-5
- > material: aluminium, untreated

Designation	Item number
Lashing 5502 air 6,000 mm bare	21550220-6000
Lashing 5502 air 3,000 mm bare	21550220-3000
Lashing 5502 air 2,000 mm bare	21550220-2000

### LC strength

WIS end fitting	382	380
Z 90°	500 daN	1,000 daN
X-Z 45°	500 daN	1,000 daN
Y-Z 45°	400 daN	900 daN

LC strength for mounting: every 75 mm with a countersunk screw M6 DIN 7991 10.9

## End cap in click version

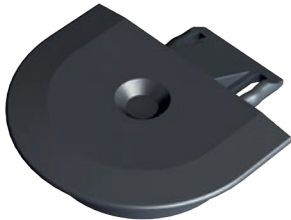

### Technical data

- > for airline track Type 5502
- > colour: black

Designation	Item number
End cap for lashing track 5502	215102001540

## Rail with lashing rods 4710

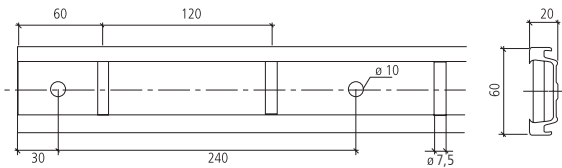

### Technical data

- > with rubber protection
- > rail width: 66 mm (incl. protective profile)
- > rail height: 23 mm (incl. protective profile)
- > rod diameter: 8 mm
- > hole pitch: Ø 10 mm, grid: 240 mm
- > pin: Ø 7.5 mm, grid: 120 mm
- > aluminium, untreated

Designation	Item number
Lashing rods 4710 6000 mm	21471020-6000
Lashing rods 4710 3000 mm	21471020-3000
Lashing rods 4710 2000 mm	21471020-2000

## End cap



### Technical data

- > for 4710 rail with lashing rods
- > color: black

Designation	Item number
Lashing rods 4710 end cap black	212106661540

## Anchor combination lashing rail 3009

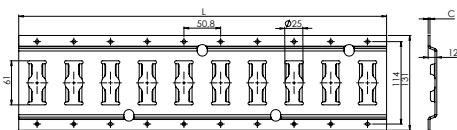
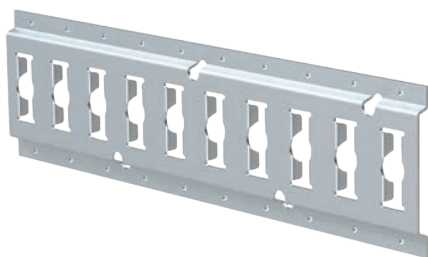

### Technical data

- > with drain hole
- > rail width: 131 mm
- > rail height: 12 mm
- > hole pitch: 50.8 mm

Designation	Item number
Lashing anchor combination 3 mm aluminum	213009300020

## End cap

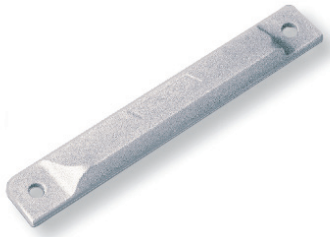

### Technical data

- > for anchor combination lashing rail type 3009
- > color: grey

Designation	Item number
Lashing combination end cap 3009 black	212109951240

## Airline lashing rail cover

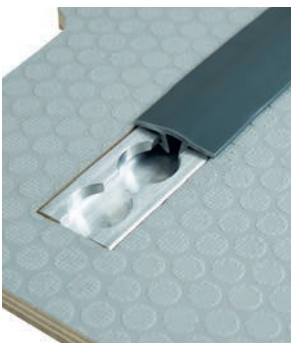

grey colour based on RAL 7011

### Technical data

- > cover for airline rails
- > standard length: 3,000 mm
- > weight: 665 g
- > material: plastic
- > color: grey

Designation	Item number
Grey 3000 mm cover profile for lashing rail 5109	21510901-3000

## Cover plug for the airline track



### Technical data

- > material: plastic
- > prevents direct contact between cargo and lashing track

Designation	Item number
Cover plug plastic airline	21510100

## LED airline lashing track 5523

**NEW!**  
Airline track with LED strips



### Electrical connection

The connection is made by a 2-core cable with 2 x 0.5 mm<sup>2</sup> cross-section.

If required, the caps can also be screwed on. For this purpose, the caps are drilled from the back with a 4.3 mm drill bit.

**Note:** The maximum voltage of the LED strip is 12.4 V. If the vehicle's electrical system is not limited to this voltage, a voltage limiter must be used to prevent the LED track from overheating.

### Technical data

- > semi-circular version with 2 integrated LED strips and 2 end caps
- > track width: 50 mm
- > track height: 10 mm
- > hole diameter: 20 mm
- > hole pattern: 25 mm
- > length of lashing track: 1,000 mm +1/-5
- > length incl. end caps: 1,080 mm +1/-5
- > material: aluminium, untreated
- > nominal voltage: 12 V
- > nominal power: 11.3 W (total power 22.6 W)
- > colour temperature: 6,500 K
- > lumen: 870 lm per strip
- > protection class: IP67
- > weight: 565 g

Available as a set of 5 with 1 m or 2 m connection cable

Designation	Item number
Lashing 5523 air 1,000 mm bare	215523770500
Lashing 5523 air 2,000 mm bare	215523770501

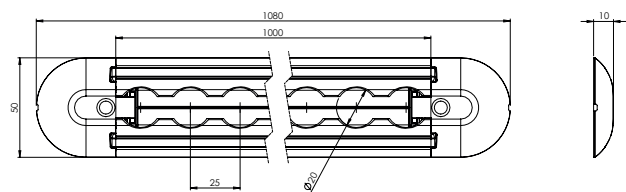



## End cap without connection terminal (click version)



### Technical data

- > for airline track Type 5523
- > colour: black

Designation	Item number
End cap click version 5523	215123011540

## End cap with connection terminal (click version)



### Technical data

- > for airline track Type 5523
- > colour: black

Designation	Item number
End cap click version 5523	215123501540

## LED strip



### Technical data

- > length: 1,025 mm +/- 5
- > incl. 45 mm connection cable
- > incl. double-sided adhesive tape on the back side
- > nominal voltage: 12 V
- > nominal power: 11.3 W
- > colour temperature: 6,500 K
- > lumen: 870 lm per strip
- > protection class: IP67

Designation	Item number
Light channel 1,000 mm	21552300-1000

## Lashing point 315

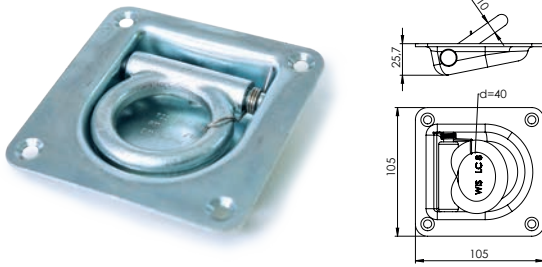

### Technical data

- > LC (lashing capacity): 800 daN
- > material: steel, galvanised
- > size: 105 x 105 mm

Designation	Item number
Lashing point 315	243150000012

## Lashing point 370

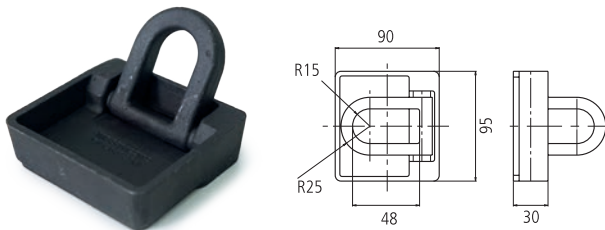

### Technical data

- > LC (lashing capacity): 2,500 daN
- > material: steel, untreated
- > size: 95 x 90 x 30 mm

Designation	Item number
Lashing point 370	243700000010

## Lashing point 360

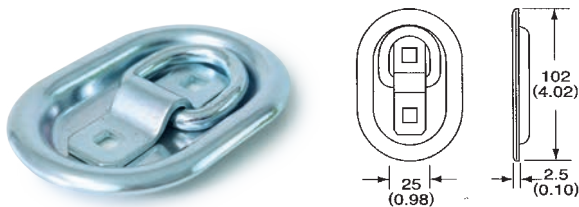

### Technical data

- > LC (lashing capacity): 350 daN
- > material: steel, galvanised
- > size: 104 x 70 mm (oval shape)

Designation	Item number
Lashing point 360	243600000012

## Lashing point 362

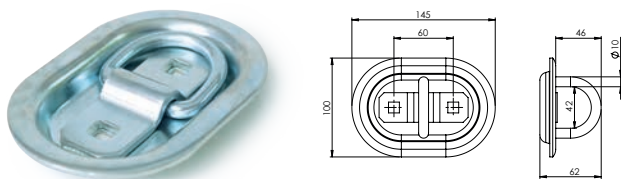

### Technical data

- > LC (lashing capacity): 800 daN
- > material: steel, galvanised
- > size: 145 x 100 mm (oval shape)

Designation	Item number
Lashing point 362	243620000012

## Screw-in fitting



### Technical data

- > thread: M8
- > LC (lashing capacity): 500 daN
- > incl. drive-in nut

Designation	Item number
Screw-in fitting M8 incl. drive-in nut	140000037701

## U-Clamps



### Technical data

- > suitable for attaching 25 mm straps
- > material: steel, galvanised
- > overall length: 68 mm
- > overall width: 15 mm
- > overall height: 15 mm
- > hole spacing: 52 mm
- > mounting holes for 5 mm rivets
- > weight: ca. 22 g

Designation	Item number
U-Clamps 15 x 52	950300001812



Suitable for use with the WTR 1000 ratchet lashing strap  
**WTR 1000 ratchet lashing strap**

- > strap: 25 mm, blue

Designation	Item number
WTR 1000-025 0.3 + 3.2 m signal blue SN	1251293

## Single airline fitting 382



### Technical data

- > LC (lashing capacity): 500 daN
- > housing made of plastic
- > colour of plastic: blue

Designation	Item number
End fitting 382 WIS single airline fitting blue	140000038200

## Single airline fitting 385



### Technical data

- > LC (lashing capacity): 500 daN
- > housing made of plastic
- > colour of plastic: red

Designation	Item number
End fitting 385 WIS single airline fitting red	140000038500

## Single airline fitting 386



### Technical data

- > LC (lashing capacity): 500 daN
- > housing made of plastic
- > colour of plastic: black

Designation	Item number
End fitting 386 WIS single airline fitting black	140000038600

## Single airline fitting 387



### Technical data

- > LC (lashing capacity): 500 daN
- > housing made of plastic
- > spring, ring and holding pin made of stainless steel
- > colour of plastic: anthracite

Designation	Item number
End fitting 387 single airline anthracite stainless steel	140000038700

## Single airline fitting 388



### Technical data

- > LC (lashing capacity): 500 daN
- > housing made of plastic
- > colour of plastic: orange

Designation	Item number
End fitting 388 WIS single airline orange	140000038800

## Single airline fitting 379



### Technical data

- > LC (lashing capacity): 500 daN
- > ring diameter (inner): 34 mm
- > material: steel, aluminium

Designation	Item number
End fitting 379 for airline track	140000037900

## Double airline fitting 380



### Technical data

- > LC (lashing capacity): 10 kN
- > material: steel, galvanised

Designation	Item number
End fitting 380 airline track double	140000038000

## Double airline fitting 381



### Technical data

- > LC (lashing capacity): 400 daN
- > ring diameter (inner): 25 mm
- > material: steel, galvanised

Designation	Item number
End fitting 381 airline track double	140000038100

## Quattro airline fitting 383



### Technical data

- > LC (lashing capacity): 25 kN
- > material: steel, galvanised

Designation	Item number
End fitting 383 airline track 4-fold	140000038300

## Airline lashing point



### Technical data

- > including 2 mounting holes
- > mounting holes: M5 countersunk head
- > diameter: 45 mm
- > material: aluminium, untreated

Designation	Item number
Lashing 5600 air 45 mm aluminium round 5.5 mm	21560125

## Wire hooks for airline fitting



### Technical data

- > with PVC coating for hanging up cables or clothing
- > carrying capacity: 50 kg

Designation	Item number
End fitting 527 wire hook for 382 etc.	140000052700

## Slot nut with two threaded holes M6



### Technical data

- > for fixing different materials to airline lashing tracks
- > material: steel, galvanised
- > size: 50 x 18 mm
- > distance between threaded holes: 25 mm

Designation	Item number
Slot nut 2 x M6 thread	215108200612

## Slot nut with three threaded holes M6



### Technical data

- > for fixing different materials to airline lashing tracks
- > material: steel, galvanised
- > size: 75 x 18 mm
- > distance between threaded holes: 25 mm

Designation	Item number
Slot nut 3 x M6 thread	215108300612

## Screw fitting with self-locking nut for airline lashing tracks



### Technical data

- > thread: M8 x 25 / 30 / 40 / 60
- > material: steel, galvanised
- > pre-assembled

Designation	Item number
Screw fitting 5107 M8 x 25 with nut and shim, clamping range until 7 mm	21510784
Screw fitting 5107 M8 x 30 with nut and shim, clamping range until 11 mm	21510785
Screw fitting 5107 M8 x 40 with nut and shim, clamping range until 22 mm	21510786
Screw fitting 5107 M8 x 60 with nut and shim, clamping range until 42 mm	21510787

## Screw-through fitting with plastic star grip for airline lashing tracks



### Technical data

- > thread: M8 x 25 / 30 / 40 / 60
- > material: steel, galvanised
- > pre-assembled

Designation	Item number
Screw fitting 5108 M8 x 25 with star grip, clamping range until 8 mm	21510824
Screw fitting 5108 M8 x 30 with star grip, clamping range until 12 mm	21510825
Screw fitting 5108 M8 x 40 with star grip, clamping range until 22 mm	21510826
Screw fitting 5108 M8 x 60 with star grip, clamping range until 41 mm	21510827

## Shovel holder with rubber band



### Technical data

- > length of the rubber band: 60 mm / 80 mm

Designation	Item number
Shovel holder with elastic band 60 mm	392003
Shovel holder with elastic band 80 mm	392004

## Edge protection 2500



### Technical data

- > for strap width 25 mm
- > material: plastic
- > colour: black
- > weight: 22 g
- > side length: 55/95 mm

Designation	Item number
Edge protection black 25 mm	162500000040



# WISTRA AirlineStop

**NEW!**  
AirlineStop for safe transport



Scan QR code and watch video

[You can find the video here.](#)

## Against pallet slipping on the loading space

With this AirlineStop, pallets can be secured against slipping on the loading space. The fitting can be used directly as a blockage in combination with integrated airline rails in the vehicle floor.

Suitable holding profiles between two fittings are **50 x 50 mm aluminum profiles**, WISTRA article numbers: **221851-1975** and **221851-1000**.

It is also possible to use a locking bar with a 19 mm pin at the ends. Due to the symmetrical design of the article, there are no different fittings for the left or right side.

In illustration B you can see the application of the article tilted by 90 degrees. For this application we recommend securing the connection with a pin / split of the aluminum profile.

221851-1000 arba 1975 susideda iš 1 vnt 221104001000 arba ..1975 ir 2vnt 14000004000

## Technical data

- > for profiles up to 50 mm thickness
- > BC (breaking capacity) 400 daN
- > material: steel, galvanised
- > size: 85 mm x 50 mm x 56,5 mm
- > weight: 410 g
- > height above the vehicle floor: 49 mm
- > center hole:  $\varnothing$  20 mm for  $\varnothing$  19 mm spigots
- > 4 x 6 mm hole for dowel pins

### Also available as a set:

- Set 1: 2x AirlineStop, 1x aluminum profile (length 1.000 mm)
- Set 2: 2x AirlineStop, 1x aluminum profile (length 1.975 mm)

Designation	Item number
WISTRA AirlineStop	140000040000
Aluminum profile 50 x 50 mm 1000 mm	221851-1000
Aluminum profile 50 x 50 mm 1975 mm	221851-1975
WISTRA AirlineStop Set 1	221104001000
WISTRA AirlineStop Set 2	221104001975

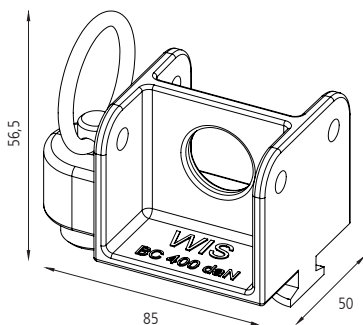

A: AirlineStop with a barrier bar



B: Lateral application

## WTR 1000 Ratchet lashing strap



### Technical data

- > two-part - SE 0.5 m + LE 4.5 m
- > according to EN 12195-2
- > LC 500 daN with straight tension
- > STF 200 daN
- > strap: 25 mm, red

with end fitting **002** (claw hook)

Designation	Item number
WTE 1000-002 0.5 + 4.5 m red	1255107



with end fitting **025** (flat hook with safety mechanism)

Designation	Item number
WTR 1000-025 0.5 + 4.5 m red	1255216



with end fitting **379** (single airline fitting)

Designation	Item number
WTR 1000-379 0.5 + 4.5 m red	11909023790545

## WTR 1000 Ratchet lashing strap



### Technical data

- > two-part – SE 0.2 m + LE 0.73 m / SE 0.2 m + LE 3.2 m
- > according to EN 12195-2
- > LC 500 daN with straight tension
- > STF 200 daN
- > strap: 25 mm, signal blue
- > The long end is connected to the short end by a safety seam.

with end fitting **382** (single airline fitting)

Designation	Item number
WTR 1000-382 0.2 + 0.73 m signal blue SN	1251286



with end fitting **201** (flat hook)

Designation	Item number
WTR 1000-201 0.2 + 3.2 m signal blue SN	1250678



with end fitting **025** (flat hook with safety mechanism)

Designation	Item number
WTR 1000-025 0.3 + 3.2 m signal blue SN	1251293

## WTR 800 Ratchet lashing strap



### Technical data

- > two-part - SE 0.5 m + LE 4.5 m
- > according to EN 12195-2
- > LC 400 daN with straight tension
- > STF 200 daN
- > strap: 25 mm, grey, yellow

with end fitting **202** (stainless steel snap hook)

Designation	Item number
WTR 800-202 0.5 + 4.5 grey	1250990



with end fitting **202** (snap hook)

Bezeichnung	Artikelnummer
WTR 800-202 0.2 + 1.8 m signal blue	1250812



with end fitting **002** (claw hook)

Designation	Item number
WTR 800-002 0.5 + 4.5 m yellow	1257988



with end fitting **025** (flat hook with safety mechanism)

Designation	Item number
WTR 800-025 0.5 + 4.5 m yellow	11906030250545



with end fitting **379** (single airline fitting)

Designation	Item number
WTR 800-379 0.5 + 4.5 m yellow	1258794

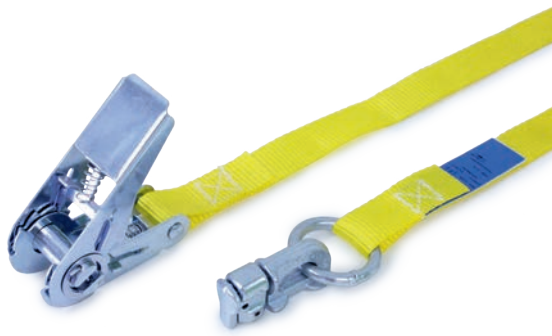

with end fitting **381** (double airline fitting)

Designation	Item number
WTR 800-381 0.5 + 4.5 m yellow	1259052

## WTR 800 Pressure ratchet lashing strap

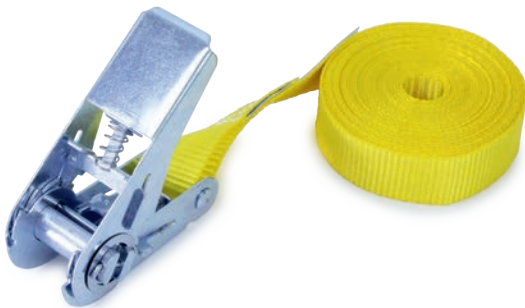

### Technical data

- > single-part – 3.0 m / 5.0 m
- > according to EN 12195-2
- > lashing capacity LC 800 daN in strapping
- > strap: 25 mm, yellow

Designation	Item number
WTR 800 single-part 3.0 m yellow	1259473
WTR 800 single-part 5.0 m yellow	1259475

## WTR 1500-826 Ratchet lashing strap



### Technische Daten

- > two-part – FE 0,5
- > according to EN 12195-2
- > LC 750 daN with straight tension
- > STF 210 daN
- > with end fitting **826** (for Combi and Anchor Combi lashing rails)
- > strap: 50 mm, green

Bezeichnung	Artikelnummer
WTR 1500-826 0.2 + 0.8 green SN*	1500533
WTR 1500-826 0.2 + 1.8 green	1504226
WTR 1500-826 0.5 + 2.5 green	1504250
WTR 1500-826 0.5 + 4.5 green	1504252

\* SN = securing seam (fixed and loose ends can not be separated) – e.g. for gas bottle holder

## WTK 350 cam buckle strap



### Technical data

- > single-part – 3.0 m / 5.0 m
- > according to EN 12195-2
- > LC 350 daN in strapping
- > strap: 25 mm, yellow

Designation	Item number
WTK 350 single-part 3.0 m yellow	1253673
WTK 350 single-part 5.0 m yellow	1253675

## WTW 250 Automatic ratchet lashing strap



### Technical data

- > two-part – SE 0.2 m + LE 2.0 m
- > based on EN 12195-2
- > LC 125 daN with straight tension
- > STF 27 daN
- > strap: 25 mm, black

with end fitting **002** (claw hook)

Designation	Item number
WTW 250-002 0.2 + 2.0 m black	1250337

with end fitting **025** (flat hook with safety mechanism)

Designation	Item number
WTW 250-025 0.2 + 2.0 m black	1250293

with end fitting **382** (single airline fitting)

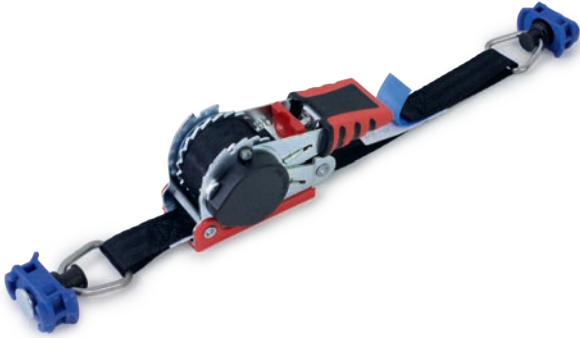

Designation	Item number
WTW 250-382 0.2 + 2.0 m black	1250346

with end fitting **725** (S-hook with PVC cover)



Designation	Item number
WTW 250-725 0.2 + 2.0 m black	1250150

## WISTRA Safeguard cargo securing nets



For more than 20 years, WISTRA GmbH has also been offering cargo securing nets in its product range.

We offer a wide range of applications – even beyond the realms of cargo securing. The common lashing strap widths 25 mm, 35 mm and 50 mm and the different mesh apertures in combination with connection adapters for the vehicle or trailer, offer a variety of options.

We could implement more than 300 different versions for our customers up to now. The Safeguard cargo securing nets are planned and manufactured according to customer requirements.

Besides many individual products, customer-specific solutions have proven invaluable and have been manufactured more than 10,000 times.

Key application areas include:

- › rear cargo securing in closed bodies, the various swap bodies, containers and special containers
- › lateral cargo securing, e.g. for curtainsiders
- › cargo securing over the cargo on the floor and to the sides
- › retention nets for short timber transports
- › restraining nets for transporters
- › tie-down lashing cargo securing nets

***Production, marking and testing are carried out in accordance with VDI Guideline 2700 Sheet 3.3 (and in accordance with DIN EN 12195-2).***







This results in a multitude of design possibilities, which are to be determined on the basis of years of experience at WISTRA and on the basis of the customer's requirements specification.

The following key data must be taken into account:

- use, handling and load data
- mesh size and fabric insert
- quantity and kind of tensioning and connecting elements
- use of linkages
- use of additional anti-theft devices

Safeguard load securing nets are manufactured for renowned customers like Deutsche Post, GLS, Hermes and many others, and have proven their practical worth across Europe.

In this catalogue, you will find a selection of net options. Please contact us if these do not meet your requirements. The WISTRA team is at your disposal with its many years of experience and also produces nets individually in quantities from 1 piece.



## "QuickKEP" cargo securing net



### Technical data

- > vertical transporter cargo securing net
- > strap width: 25 mm
- > strap colour: red
- > with aluminium rods both sides
- > 2 mounting levels for hanging up
- > adapted to the contour of the MB Sprinter – Height 2
- > LC net mounting point 250 daN
- > LC net total 600 daN
- > mesh check, production and marking according to VDI guideline 2700 Part 3.3
- > net height approx. 1,700 mm
- > weight net: approx. 6.8 kg
- > weight fitting 380 total: approx. 1.8 kg

### Side mounting

- > WIS hook-in device for double airline fitting 380
- > 16 double airline fittings are already included in the set

### Packed as a set for MB Sprinter – Height 2

Designation	Item number
Safeg QuickKEP Sprinter H2	273480000000

### Packed as a set for VW Crafter

Designation	Item number
Safeg QuickKEP Crafter	273480000400

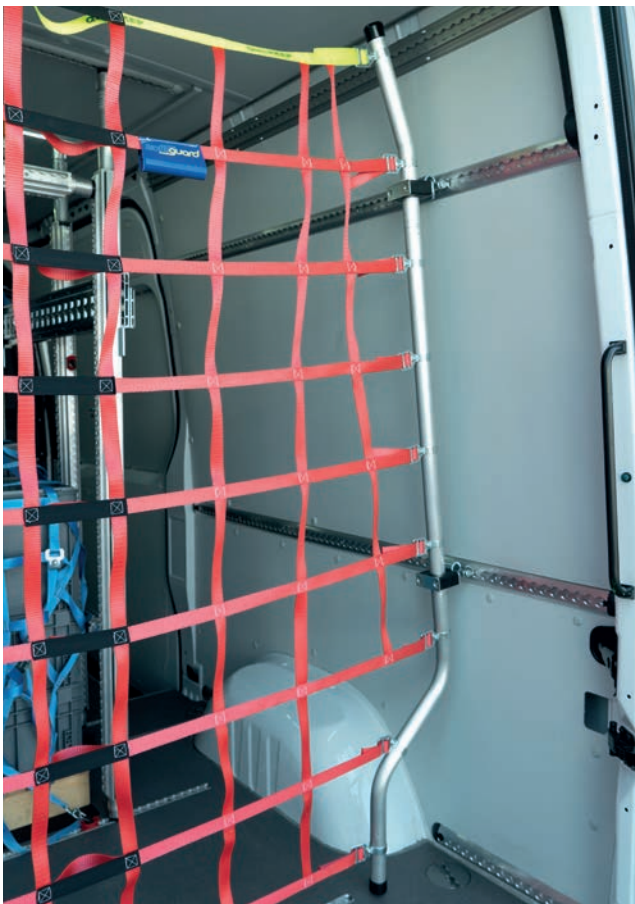

## "QuickKEP" dimensions

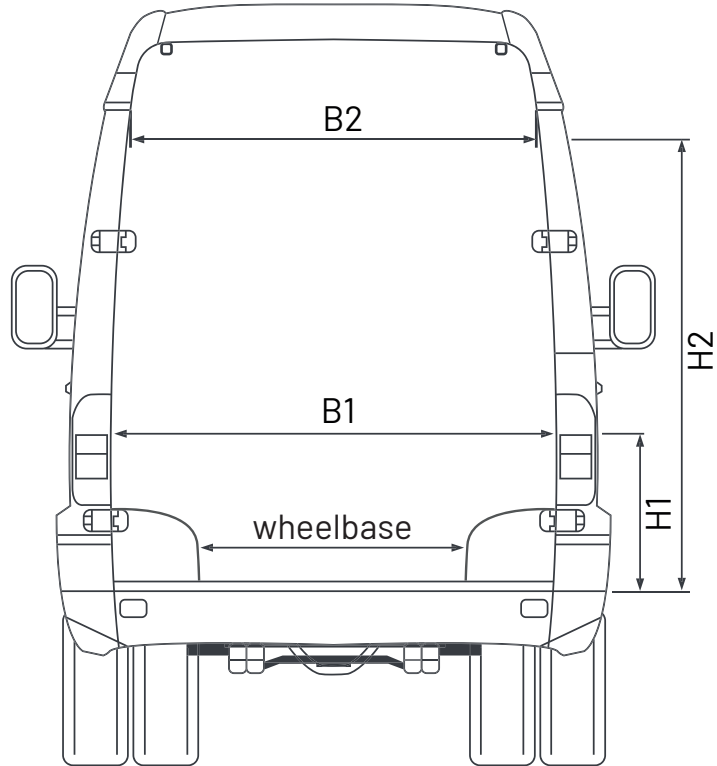

<b>company</b>	
<b>vehicle manufacturer</b>	
<b>vehicle model</b>	
<b>H1</b>	
<b>B1</b>	
<b>H2</b>	
<b>B2</b>	

[Click here for the online form.](#)

## "QuickMED" medium cargo securing net



### Technical data

- > suitable for Citroën Jumpy, Fiat Talento, Ford Transit Connect, MB Vito, Opel Vivaro, Renault Trafic, VW T5 / T6, as well as other models
- > vertical pickup truck load safety net
- > is locked by spring pressure on the bottom pin in the hooking device
- > strap width: 25 mm
- > with aluminium rods both sides
- > 2 mounting levels for hanging up
- > LC net mounting point 250 daN
- > LC net total 600 daN
- > mesh check, production and marking according to VDI guideline 2700 Part 3.3
- > net height approx. 1,200 mm
- > weight net: approx. 4.8 kg
- > weight fitting 380 total: approx. 900 g

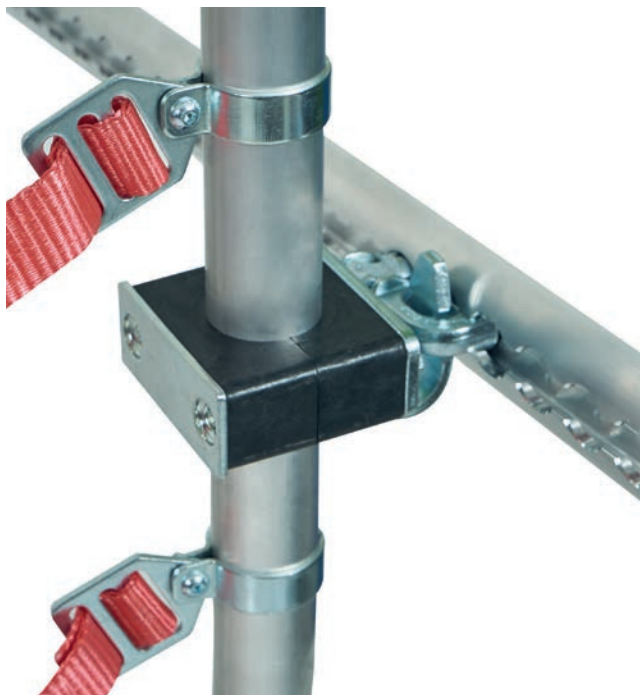

### Side mounting

- > WIS hook-in device for double airline fitting 380
- > 8 double airline fittings are already included in the set

### Packed as a set

Designation	Item number
Safeg QuickMED medium	274290000100



## "QuickMED" small cargo securing net



### Technical data

- > suitable for Citroën Berlingo, Fiat Doblo, Ford Transit Courier, MB Citan, Opel Combo, Renault Kango, VW Caddy, as well as other models
- > vertical pickup truck load safety net
- > is locked by spring pressure on the bottom pin in the hooking device
- > strap width: 25 mm
- > with aluminium rods both sides
- > 2 mounting levels for hanging up
- > LC net mounting point 250 daN
- > LC net total 600 daN
- > mesh check, production and marking according to VDI guideline 2700 Part 3.3
- > net height approx. 1,080 mm
- > weight net: approx. 4,3 kg
- > weight fitting 380 total: approx. 900 g

### Side mounting

- > WIS hook-in device for double airline fitting 380
- > 8 double airline fittings are already included in the set

### Packed as a set

Designation	Item number
Safeg QuickMED small	274290000200

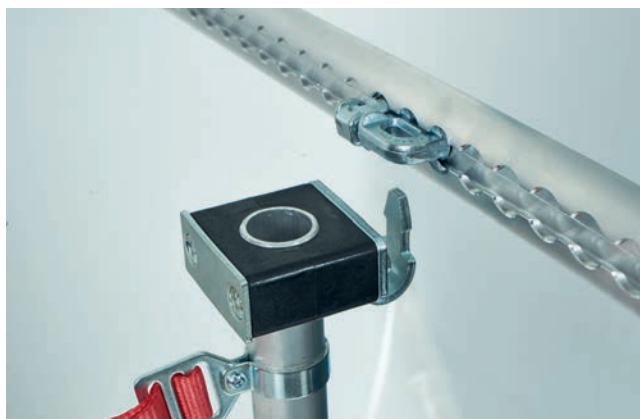

## "QuickMED" medium und small dimensions

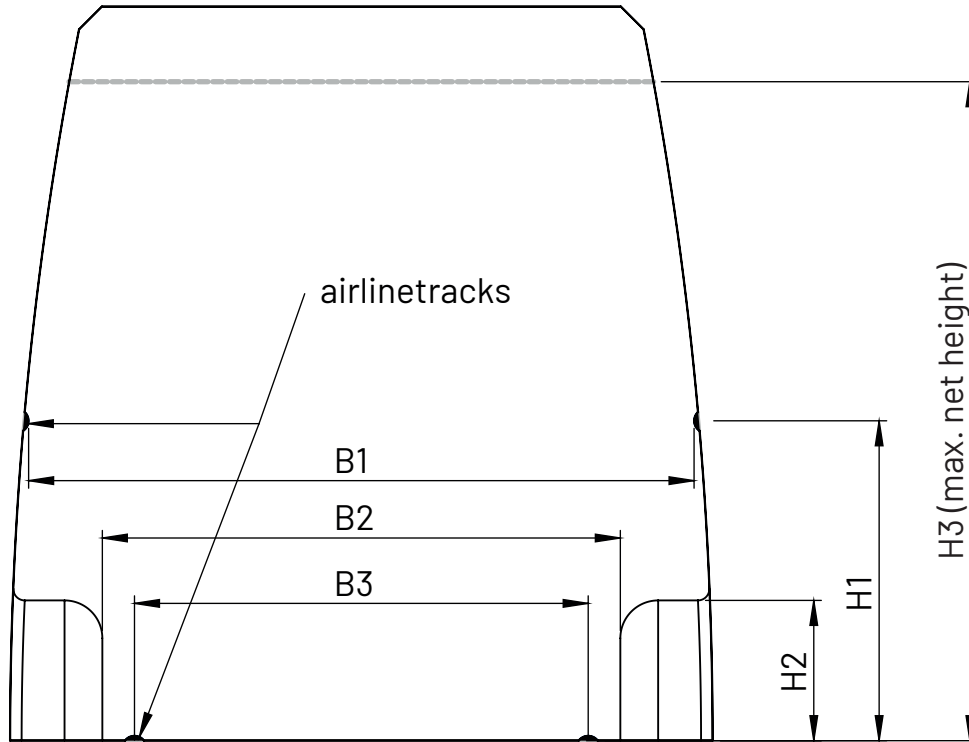

102

<b>company</b>	
<b>vehicle manufacturer</b>	
<b>vehicle model</b>	
<b>H1</b>	
<b>B1</b>	
<b>H2</b>	
<b>B2</b>	
<b>H3</b>	
<b>B3</b>	

[Click here for the online form.](#)

## Cargo securing net "4 levels"



### Technical data

- > for MB Sprinter / VW Crafter Height 2
- > vertical transport net
- > strap width: 25 mm
- > strap colour: red
- > mesh size approx. 175 x 175 mm.
- > 4 mounting levels
- > width approx. 1,450/1,700 mm x height approx. 1,700 mm
- > LC net mounting point 200 daN
- > LC net total 400 daN
- > mesh check, production and marking according to VDI guideline 2700 Part 3.3
- > net height approx. 1,800 mm

The following end fittings are included per box:

- > 8 x end fitting 382 for airline lashing tracks
- > 8 x end fitting 025 for track with pins

#### Side mounting

- > on both sides by means of attached clamp lock
- > four mounting levels measured from the floor approx. 50 mm / 700 mm / 1,540 mm / 1,800 mm
- > net width
  - mounting level with approx. 50 mm: approx. 1,600 mm,
  - mounting level with approx. 700 mm: approx. 1,600 mm
  - mounting level with approx. 1,540 mm: approx. 1,400 mm
  - mounting level with approx. 1,800 mm: 1,350 mm

#### Packed as a set

Designation	Item number
Safeg 25 Crafter/Sprinter 4 levels	271350000008

## WISTRA alcove netting

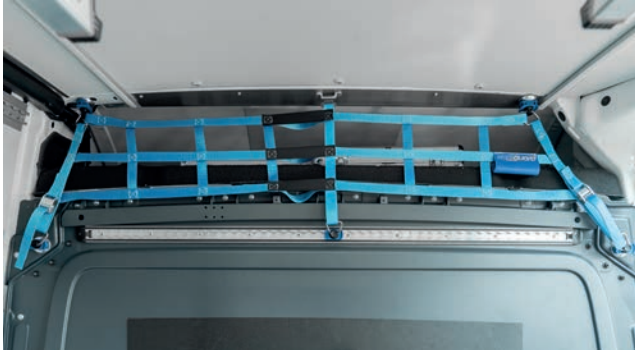

### Technical data

- > load securing net for the storage space above the cab
- > adapted to the contour of the MB Sprinter - Hight 2
- > strap width: 25 mm
- > strap colour: blau
- > LC net mounting point 200 daN
- > LC net total 150 daN
- > mesh check, production and marking according to VDI guideline 2700 Part 3.3
- > net height approx. 215 mm
- > weight net: 900 g
- > attachment with 5x fitting 382 and hook 213
- > 5x round airline attachment points, 1x flat hook as well as 1x hooks and clamps are included in the set

### Packed as a set

Designation	Item number
Safeg alcove network for Sprinter H2	2743101



## Cargo securing net for tie-down lashing with ratchets



### Technical data

- > size: 1,575 x 1,350 mm
- > mesh size: 200 x 200 mm
- > strap width: 25 mm wide
- > strap colour: red
- > 14 D-rings 703 are sewn circumferentially around the net
- > additionally 4 end fittings 025 on each of the short sides
- > including 4 fastening straps WTR 1000 single-part 4.0 m red
- > including 4 freewheeling standard claw hooks 002
- > mesh check, production and marking according to VDI guideline 2700 Part 3.3

### Packed as a set

Designation	Item number
Safeg 25 1,575 x 1,350 mm MW 200 Standard 2010	272130000000

## Cargo securing net for low tensioning with clamping locks



### Technical data

- > size: 1,375 x 1,225 mm
- > mesh size: 125 x 125 mm
- > strap width: 25 mm
- > strap colour: blue
- > 1 end fitting 025 at each corner
- > additionally 4 end fittings 025 tapering inwards inside net
- > for adaptation with clamping lock 605 and long end with end fitting 025 length 1.0 m
- > clamping locks and long ends are included in the net
- > mesh check, production and marking according to VDI guideline 2700 Part 3.3

### Packed as a set

Designation	Item number
Safeg 25 1,375 x 1,225 mm MW 125 blue	272220000001

## Cargo securing net for tensioning down

①

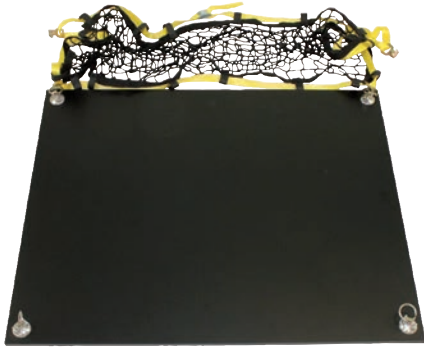

②



③



④



### Technical data

Consisting of:

- > 1 x cargo securing net  
basis of VDI 2700 Part 3.3  
material: knitted yarn  
material thickness: 3 mm  
mesh size approx. 45 mm.  
maximum mesh tensile force: approx. 1,250 N  
yarn colour: black  
all around with edging tape in black  
and 20 strap loops
- > 1 x WTK 500 single-part 4,100 mm yellow
- > 4 x end fitting **002** (claw hook) / **725** (S-hook with PVC cover) / **201** (flat snap hook) / **025** (flat hook with safety mechanism) / **382** (single airline fitting)
- > LC net total: 400 daN
- > LC net mounting point: 400 daN
- > packaging: bagged with sticker
  
- > size: 1,290 x 730 mm

Designation	Item number
Safeg 1,250 x 730 mm knitted WTK WIS 002 yellow	272830002210
Safeg 1,250 x 730 mm knitted WTK WIS 725 yellow	272830725210
Safeg 1,250 x 730 mm knitted WTK WIS 201 yellow	272830201210
Safeg 1,250 x 730 mm knitted WTK WIS 025 yellow	272830025210
Safeg 1,250 x 730 mm knitted WTK WIS 382 yellow	272830382210

- > size: 2,290 x 1,500 mm

Designation	Item number
Safeg 2,290 x 1,500 mm knitted WTK WIS 002 yellow	272940002210
Safeg 2,290 x 1,500 mm knitted WTK WIS 725 yellow	272940725210
Safeg 2,290 x 1,500 mm knitted WTK WIS 201 yellow	272940201210
Safeg 2,290 x 1,500 mm knitted WTK WIS 025 yellow	272940025210
Safeg 2,290 x 1,500 mm knitted WTK WIS 382 yellow	272940382210



## WISTRA WheelNet

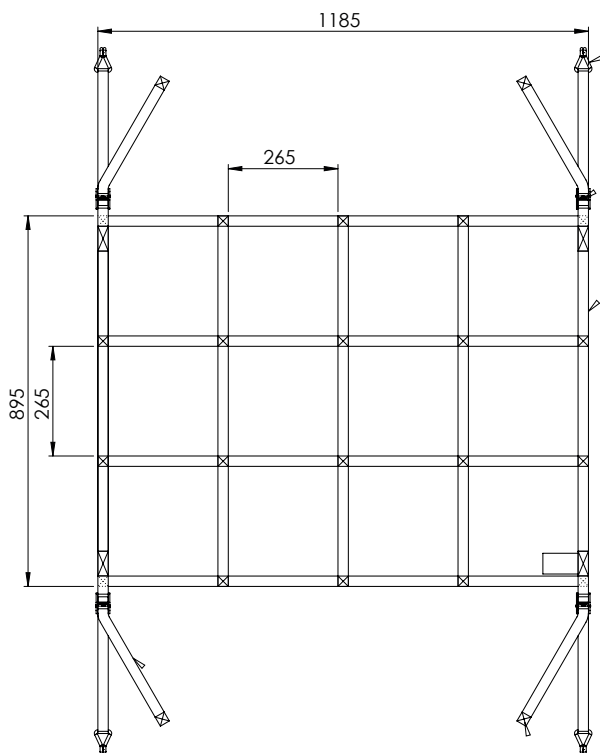

### Technical data

- > size: 1185 x 895 mm
- > mesh size: 265 x 265 mm
- > strap width: 25 mm
- > strap colour: rot
- > LC net total: 300 daN
- > 4 x end fitting 002
- > 4 x clamping lock 25 mm
- > weight net: approx. 1,16 kg

Designation	Item number
Safeg tire net for trunk	274300000000

## Covering nets

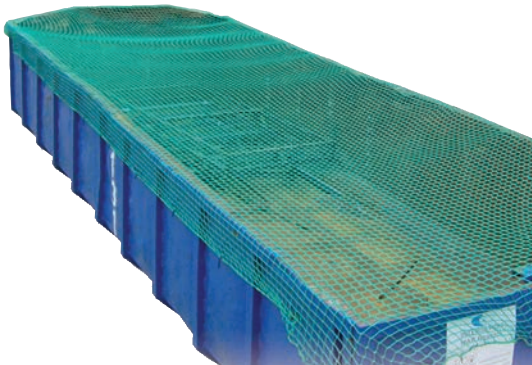
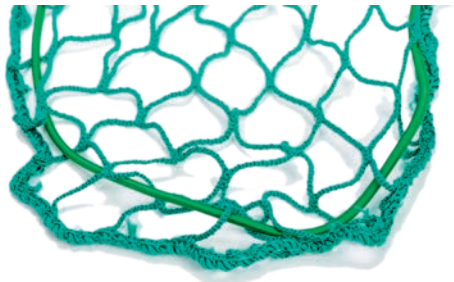

### Technical data

- > cover net made of PPM knotless
- > according to VDI 2700, sheet 3.3
- > mesh size: 30 x 30 mm
- > material thickness: 2 mm
- > net colour: green
- > with edge hem and circumferential rubber rope

Designation	Item number
Net cover 2 mm MW 30 1.4 x 2.3 m	275200312314
Net cover 2 mm MW 30 1.8 x 3.3 m	275200313318
Net cover 2 mm MW 30 2.0 x 3.0 m	275200312030
Net cover 2 mm MW 30 2.0 x 3.5 m	275200312035
Net cover 2 mm MW 30 2.5 x 3.5 m	275200313525
Net cover 2 mm MW 30 2.5 x 4.5 m	275200314525
Net cover 2 mm MW 30 4.5 x 3.0 m	275200314530

- > cover net made of PPM knotless
- > mesh size: 50 x 50 mm
- > material thickness: 3 mm
- > net colour: green
- > with edge hem and circumferential rubber rope

Designation	Item number
Net cover 3 mm MW 50 1.5 x 2.2 m	275300511522
Net cover 3 mm MW 50 1.5 x 2.5 m	275300511525
Net cover 3 mm MW 50 1.5 x 2.7 m	275300512715
Net cover 3 mm MW 50 2.0 x 3.0 m	275300512030
Net cover 3 mm MW 50 2.5 x 3.5 m	275300512535
Net cover 3 mm MW 50 2.5 x 4.5 m	275300514525
Net cover 3 mm MW 50 3.0 x 3.5 m	275300513035
Net cover 3 mm MW 50 3.0 x 4.0 m	275300513040
Net cover 3 mm MW 50 3.5 x 5.0 m	275300513550
Net cover 3 mm MW 50 3.5 x 5.5 m	275300515535
Net cover 3 mm MW 50 3.5 x 6.0 m	275300513560
Net cover 3 mm MW 50 3.5 x 7.0 m	275300513570
Net cover 3 mm MW 50 3.5 x 8.0 m	275300513580

## Rubber rope for cover nets



### Technical data

- > thickness: 6 - 8 mm
- > colour: white

Designation	Item number
Net accessories rubber rope 6 mm FO white	2756000G0001

## Shoring beam "Airline Beam" 1855

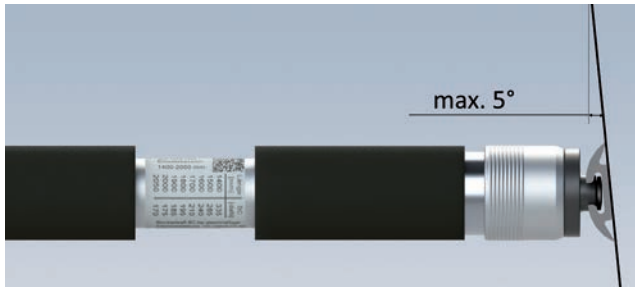

### Product description

Used in conjunction with airline lashing tracks running parallel in the vehicle, the trailer or other means of transport, the Airline Beam ensures cargo securing with positive locking. The Airline Beam can be used horizontally and vertically for cargo securing. The automatic airline pins on both sides snap into one pair of holes in each of the airline lashing tracks.

#### 1. unlocking



#### 2. inserting

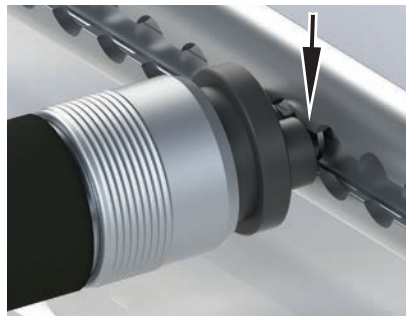

#### 3. shifting

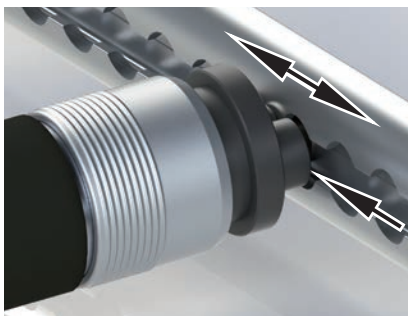

#### 4. locking

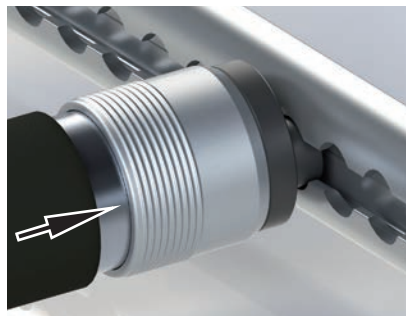

Example of a label:  
Can be customised with your logo and your address on request!

### Advantages

- > suited for horizontal and vertical application
- > In conjunction with non-slip materials, cargo with a weight of up to 2,250 kg can be secured in the direction of travel using one Airline Beam.
- > smooth and continuous telescopic adjustment
- > no protruding operating controls over its entire range
- > supporting tube and hand piece with PVC coating for comfortable handling even in cold outside temperatures, as well as for protection of the load
- > The automatic airline pins on both sides snap into one pair of holes in each of the airline lashing tracks.
- > The automatic airline pins do not damage the material within the airline lashing track.
- > When the Airline Beam is inserted by the user, no simultaneous pressure in both directions is required.
- > The airline automatic spigot is prevented from slipping out by a locking mechanism activated by applying pressure to the side panel.
- > Thanks to the locking mechanism in the airline lashing track, the system does not damage the transport vehicle.



## Shoring beam "Airline Beam" 1855



### Technical data

- > with PVC coating in black
- > support tube diameter: 42 mm
- > both sides with innovative automatic pin for the airline lashing track
- > with pull-out stop for 150 mm telescopic distance

Designation	possible field of application	Blocking capacity	Item number
Airline Beam 1855 650 mm WIS black bare	650 – 760 mm	550 – 675 daN	221855-150-0650
Airline Beam 1855 800 mm WIS black bare	800 – 910 mm	475 – 600 daN	221855-150-0800
Airline Beam 1855 900 mm WIS black bare	900 – 1,010 mm	450 – 575 daN	221855-150-0900
Airline Beam 1855 1000 mm WIS black bare	1,000 – 1,110 mm	425 – 550 daN	221855-150-1000
Airline Beam 1855 1100 mm WIS black bare	1,100 – 1,210 mm	400 – 550 daN	221855-150-1100
Airline Beam 1855 1200 mm WIS black bare	1,200 – 1,310 mm	400 – 525 daN	221855-150-1200
Airline Beam 1855 1300 mm WIS black bare	1,300 – 1,410 mm	375 – 525 daN	221855-150-1300
Airline Beam 1855 1400 mm WIS black bare	1,400 – 1,510 mm	375 – 500 daN	221855-150-1400
Airline Beam 1855 1500 mm WIS black bare	1,500 – 1,610 mm	375 – 450 daN	221855-150-1500
Airline Beam 1855 1600 mm WIS black bare	1,600 – 1,710 mm	375 – 425 daN	221855-150-1600
Airline Beam 1855 1700 mm WIS black bare	1,700 – 1,810 mm	350 – 400 daN	221855-150-1700
Airline Beam 1855 1800 mm WIS black bare	1,800 – 1,910 mm	350 – 375 daN	221855-150-1800
Airline Beam 1855 1900 mm WIS black bare	1,900 – 2,010 mm	350 – 350 daN	221855-150-1900

- > with pull-out stop for 350 mm telescopic distance

Designation	possible field of application	Blocking capacity	Item number
Airline Beam 1855 900 mm WIS black bare	900 – 1,210 mm	350 – 575 daN	221855-350-0900
Airline Beam 1855 1000 mm WIS black bare	1,000 – 1,310 mm	325 – 550 daN	221855-350-1000
Airline Beam 1855 1100 mm WIS black bare	1,100 – 1,410 mm	300 – 550 daN	221855-350-1100
Airline Beam 1855 1200 mm WIS black bare	1,200 – 1,510 mm	300 – 525 daN	221855-350-1200
Airline Beam 1855 1300 mm WIS black bare	1,300 – 1,610 mm	275 – 525 daN	221855-350-1300
Airline Beam 1855 1400 mm WIS black bare	1,400 – 1,710 mm	275 – 500 daN	221855-350-1400
Airline Beam 1855 1500 mm WIS black bare	1,500 – 1,810 mm	275 – 450 daN	221855-350-1500
Airline Beam 1855 1600 mm WIS black bare	1,600 – 1,910 mm	250 – 425 daN	221855-350-1600
Airline Beam 1855 1700 mm WIS black bare	1,700 – 2,010 mm	250 – 400 daN	221855-350-1700
Airline Beam 1855 1800 mm WIS black bare	1,800 – 2,110 mm	250 – 375 daN	221855-350-1800
Airline Beam 1855 1900 mm WIS black bare	1,900 – 2,210 mm	250 – 350 daN	221855-350-1900

## Shoring beam "Airline Beam" 1855



### Technical data

- > with PVC coating in black
- > support tube diameter: 42 mm
- > both sides with innovative automatic pin for the airline lashing track
- > with pull-out stop for 600 mm telescopic distance

Designation	possible field of application	Blocking capacity	Item number
Airline Beam 1855 1100 mm WIS black bare	1,100 - 1,660 mm	250 - 550 daN	221855-600-1100
Airline Beam 1855 1200 mm WIS black bare	1,200 - 1,760 mm	225 - 525 daN	221855-600-1200
Airline Beam 1855 1300 mm WIS black bare	1,300 - 1,860 mm	225 - 525 daN	221855-600-1300
Airline Beam 1855 1400 mm WIS black bare	1,400 - 1,960 mm	225 - 500 daN	221855-600-1400
Airline Beam 1855 1500 mm WIS black bare	1,500 - 2,060 mm	200 - 450 daN	221855-600-1500
Airline Beam 1855 1600 mm WIS black bare	1,600 - 2,160 mm	200 - 425 daN	221855-600-1600
Airline Beam 1855 1700 mm WIS black bare	1,700 - 2,260 mm	200 - 400 daN	221855-600-1700
Airline Beam 1855 1800 mm WIS black bare	1,800 - 2,360 mm	200 - 375 daN	221855-600-1800
Airline Beam 1855 1900 mm WIS black bare	1,900 - 2,460 mm	200 - 350 daN	221855-600-1900

## Storage rail for "Airline Beam"



### Technical data

- > material: steel, black black KTL coated
- > to be fastened to the airline rail with a screw fitting
- > Set consists of 2 parking angles, 2 star handles with Airline screws 8 x 25
- > W x H x D: 79 x 120 x 50 mm

Designation	Item number
Storage rail for two Airline Beams along the side	215110010

## Aluminium shoring beam modular system

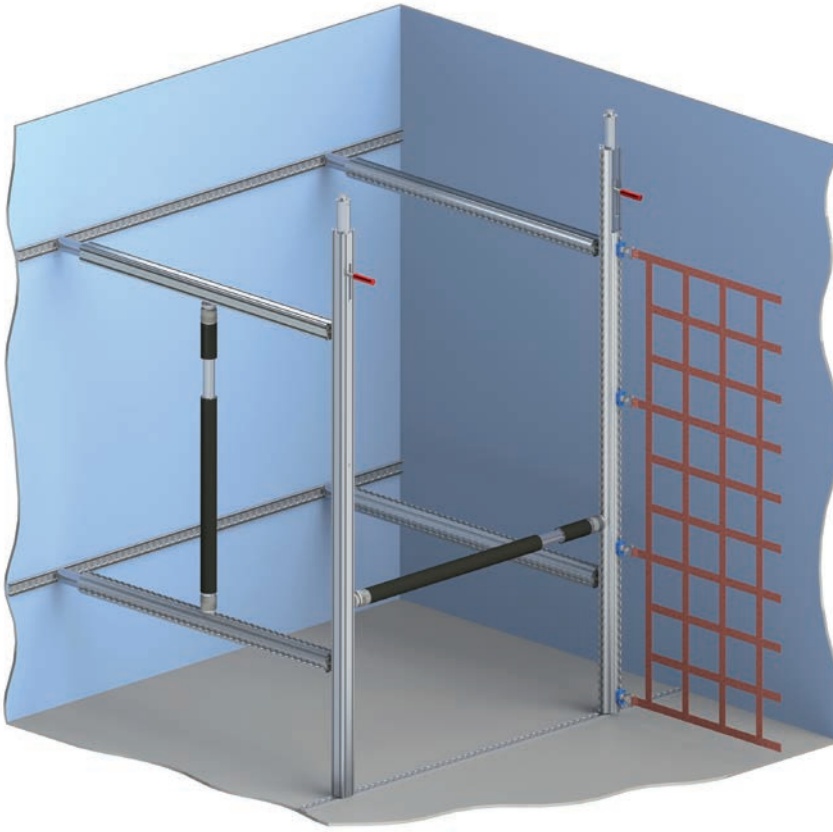

### Strength meets individuality

The new WISTRA shoring beam system is based on a new 50 x 50 mm aluminium profile. In the design phase, the focus was on the many customer requests we received.

Blocking forces BC of up to 900 daN were achieved at our in-house testing facility, depending on the version.

Its true strength is its versatility and individual connection options to the inserted airline sliding profile.

In addition to the Airline Beam 1855, WISTRA lashing straps as well as Safe-guard cargo securing nets or further accessories for the airline lashings can be used.

112

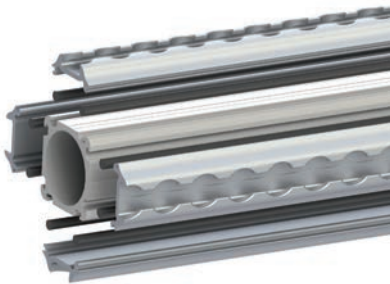

### The supporting tube

The new square shoring beams can be equipped in their basic form or additionally with inserted airline lashing tracks or with rubber protection along their entire length or in sections.

### The connection systems

In addition to the design features of the supporting tube, we offer the shoring beams with the proven compression spring telescopic tubes for perforated rail systems or freely telescopic without compressive forces with the WISTRA-Airline automatic pin in conjunction with the airline lashing tracks.



## Aluminium "Spairbalken 1851" (shoring beam)

with compression spring telescope and handle

### Pin design

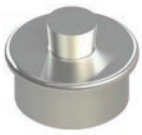

Type 09



Type 19  
non-rotating  
Ensure correct  
positioning!



Type 24



Type 25  
non-rotating  
Ensure correct  
positioning!



### for lashing track



Hole pitch  
ø 20 mm



Airline version



Hole pitch  
ø 25 mm



Combi track  
ø 25 mm

## Aluminium "Spairbalken 1857" (shoring beam)

with compression spring telescope

### Pin design

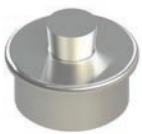

Type 09



Type 19  
non-rotating  
Ensure correct  
positioning!



Type 24



Type 25  
non-rotating  
Ensure correct  
positioning!



Type 32



### for lashing track



Hole pitch  
ø 20 mm



Airline version



Hole pitch  
ø 25 mm



Combination  
track ø 25 mm



Keyhole 34/22

# Aluminium shoring beam 1856 telescopic

## Product description

The shoring beam is used in conjunction with airline lashing tracks running parallel in the vehicle, trailer or other means of transport to ensure cargo securing with positive locking. The shoring beam can be used both horizontally and vertically for securing cargo. The automatic airline pins on both sides snap into one pair of holes in each of the airline lashing tracks.

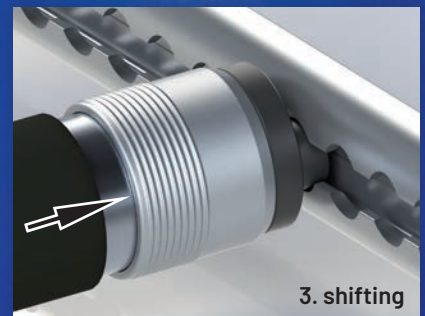
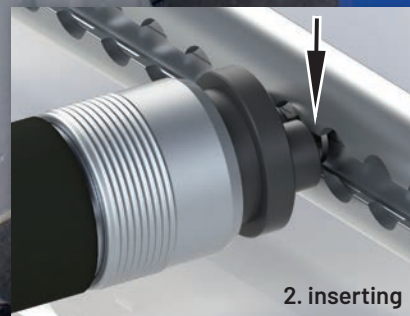

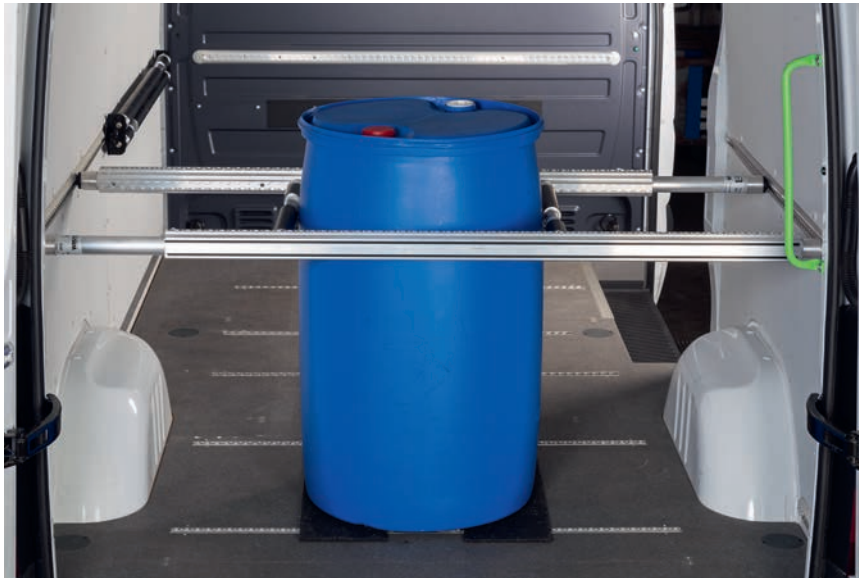
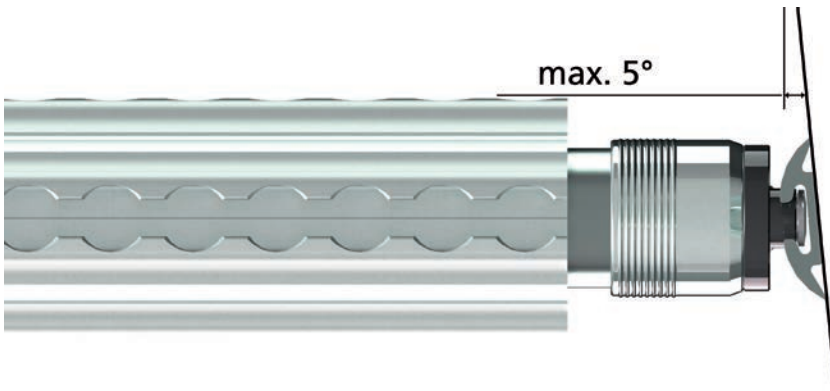

horizontal application



vertical application



## Aluminium parting wall lock 7452

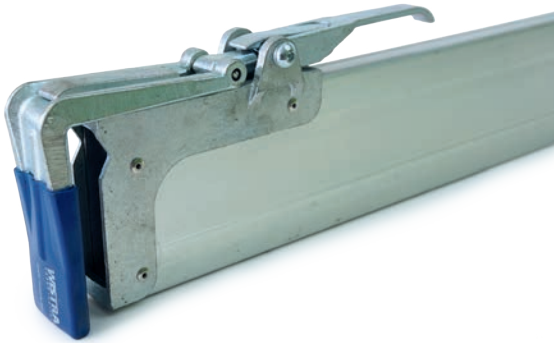

### Technical data

- > with cast end pieces
- > application range: 1,250 – 1,550 mm / 1,500 – 1,800 mm / 2,100 – 2,400 mm
- > max. blocking force: BC 400 daN for uniform area loading up to 2,700 mm
- > DEKRA-certified

Designation	Item number
Between aluminium 1,250 – 1,550 mm	2374529-1250
Between aluminium 1,500 – 1,800 mm	2374529-1500
Between aluminium 2,100 – 2,400 mm	2374529-2100

## Garment rail TA for airline lashing tracks



### Technical data

- > with the aid of 2 double-airline end fittings 380, it snaps clothes rails into airline lashing tracks
- > area of application: must be specified with each enquiry or order
- > support tube: chrome-plated
- > without spring function
- > equipped with two Velcro straps for securing the throw bar

Designation	Item number
Clothes rail TA Transp Air TR according to specification	267500000000



Hang the garment rail in the double airline fitting



Double airline fitting 380

## Carbon "QuickWall" cargo securing wall

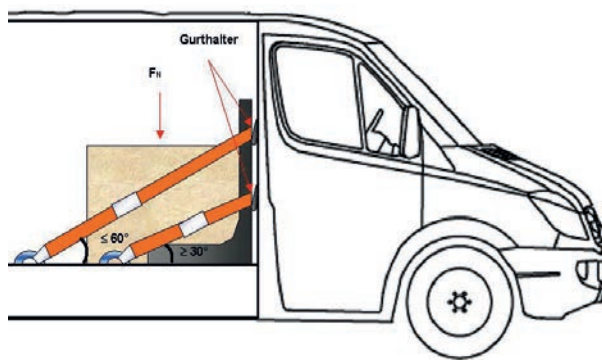

### Technical data

- > made of high-quality carbon fibre material
- > colour: black
- > in conjunction with the lashing straps used on two levels in the means of transport ensures cargo securing with positive locking
- > W x H x D: 1,190 x 800 x 360 mm
- > weight: approx. 12 kg
- > DEKRA-certified (No. 201432956 dated 17/10/2014)
- > use with RH mats and lashing straps LC 1000 daN easy and straightforward
- > the max. total payload of the QuickWall is 1,400 kg



Scan QR code and watch video

[You can find the video here](#)

**As a set incl. 2 lashing straps WTR 2200-520 0.5 + 5.5 m and 2x non-slip mat roll 1,250 x 3 x 150 mm**

Designation	Item number
Carbon wall	16920000





Top seller

## Car transport lashing strap WTA 2908

---

More on page 125



**Cargo securing for car transporters and trailers**

## Protection for long end



**Type A50**  
Rubberised hose



**Type B50**  
Fabric hose



**Type C50**  
Solid rubber controller



**Type D50**  
3 pieces abrasion blocks

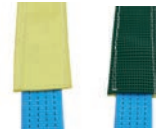

**Type E50**  
Controller with rubberised backside

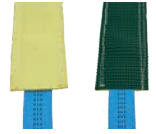

**Type E35**  
Controller with rubberised backside

## Car transport lashing strap WTA 3821



Type A50



Type B50



Type C50



Type D50

### Technical data

- > according to EN 12195-2 elongation max. 4%
- > strap width 50 mm
- > LC 1,500 daN with straight tension
- > short end with end fitting **006** (claw hook)
- > free-running end fitting **006** (claw hook)
- > long end with end fitting **006** (claw hook)
- > strap colour: blue

Designation	Item number
WTA 3821A50 006-006-006 0.2 + 2.8 m blue 4%	1500380

Designation	Item number
WTA 3821B50 006-006-006 0.2 + 2.8 m blue 4%	1503152

Designation	Item number
WTA 3821C50 006-006-006 0.2 + 2.8 m blue 4%	1503161

Designation	Item number
WTA 3821D50 006-006-006 0.2 + 2.5 m 4%	11811050060225

## Car transport lashing strap WTA 3821



Type E50

### Technical data

- › according to EN 12195-2 elongation max. 4%
- › strap width 50 mm
- › LC 1,500 daN with straight tension
- › ratchet 821 with end fitting **353** (swivel hook)
- › free-running end fitting **014** (single finger claw hook)
- › long end with end fitting **014** (single finger claw hook)
- › strap colour: blue

Designation	Item number
WTA 3821E50 353-014-014 SE + 2.3 m blue 4%	1503184

## Car transport lashing strap WTA 3921



Type E35

### Technical data

- › according to EN 12195-2 elongation max. 4%
- › strap width 35 mm
- › LC 1,500 daN with straight tension
- › short end with end fitting **356** (swivel hook)
- › free-running end fitting **354** (swivel hook)
- › long end with end fitting **354** (swivel hook)
- › loose end with securing seam
- › strap colour: blue
- › label inside, with Quick-View-Label

Designation	Item number
WTA 3921E35 356-354-354 SE + 2.8 m blue 4%QV	1351023



## Car transport lashing strap WTA 2917



### Technical data

- > according to EN 12195-2
- > LC 1,000 daN with straight tension
- > short end with end-fitting **536** (single finger claw hook)
- > without free-running end fitting
- > long end with end fitting **536** (single finger claw hook)
- > without protective hose
- > strap colour: orange
- > including blue cross-strap (figure-eight loop)
- > both sides loop 100 mm - tapered
- > total length DP/DP 351 mm

Designation	Item number
WTA 2917035 536-888-536 0.2 + 2.5 m blue	1357412L

## Car transport lashing strap WTA 2908



### Technical data

- > according to EN 12195-2
- > LC 1000 daN with straight tension
- > SE with end fitting **356** (swivel hook) directly on the ratchet
- > long end with end fitting **015** (D-ring) and protective hose 400 mm
- > measured from the hook with a length of 500 mm, a fitted EB 536 (single-finger claw hook)
- > strap colour: blue

Designation	Item number
WTA 2908035 356-536-015 SE + 1.5 m	1351235L



Top seller

## Hoisting strap

---

More on page 127



## Other products

## Lifting slings



### Technical data

- > nominal load capacity: 1,000 kg
- > width: 30 mm
- > colour: violet
- > according to EN 1492-1
- > GS-tested

Designation	Item number
Lifting strap 1000 kg 2.0 m	620100203021
Lifting strap 1000 kg 4.0 m	620100403021
Lifting strap ,000 kg 6.0 m	620100603021



### Technical data

- > nominal load capacity: 2,000 kg
- > width: 60 mm
- > colour: green
- > according to EN 1492-1
- > GS-tested

Designation	Item number
Lifting strap 2000 kg 2.0 m	620100206021
Lifting strap 2000 kg 4.0 m	620100406021
Lifting strap 2000 kg 6.0 m	620100606021
Lifting strap 2000 kg 8.0 m	620100806021



### Technical data

- > nominal load capacity: 3,000 kg
- > width: 90 mm
- > colour: yellow
- > according to EN 1492-1
- > GS-tested

Designation	Item number
Lifting strap 3000 kg 2.0 m	620100209021
Lifting strap 3000 kg 4.0 m	620100409021
Lifting strap 3000 kg 6.0 m	620100609021

## Lifting slings



### Technical data

- > nominal load capacity: 4,000 kg
- > width: 120 mm
- > colour: grey
- > according to EN 1492-1
- > GS-tested

Designation	Item number
Lifting strap 4000 kg 2.0 m	620100212021
Lifting strap 4000 kg 4.0 m	620100412021
Lifting strap 4000 kg 6.0 m	620100612021



### Technical data

- > nominal load capacity: 6,000 kg
- > width: 180 mm
- > colour: brown
- > according to EN 1492-1
- > GS-tested

Designation	Item number
Lifting strap 6000 kg 6.0 m	620100618021

## Round slings



### Technical data

- > nominal load capacity: 1,000 kg
- > useful length: 0.5 – 4.0 m
- > circumferential length: 1.0 – 8.0 m
- > colour: violet
- > according to EN 1492-2
- > GS-tested

Designation	Item number
Round sling 1t violet 1.0 m circumference	610100100027
Round sling 1t violet 2.0 m circumference	610100200027
Round sling 1t violet 3.0 m circumference	610100300027
Round sling 1t violet 4.0 m circumference	610100400027
Round sling 1t violet 5.0 m circumference	610100500027
Round sling 1t violet 6.0 m circumference	610100600027
Round sling 1t violet 8.0 m circumference	610100800027



### Technical data

- > nominal load capacity: 2,000 kg
- > useful length: 0.5 – 4.0 m
- > circumferential length: 1.0 – 8.0 m
- > colour: green
- > according to EN 1492-2
- > GS-tested

Designation	Item number
Round sling 2t green 1.0 m circumference	610200100027
Round sling 2t green 2.0 m circumference	610200200027
Round sling 2t green 3.0 m circumference	610200300027
Round sling 2t green 4.0 m circumference	610200400027
Round sling 2t green 5.0 m circumference	610200500027
Round sling 2t green 6.0 m circumference	610200600027
Round sling 2t green 8.0 m circumference	610200800027

## Round slings



### Technical data

- > nominal load capacity: 3,000 kg
- > useful length: 0.5 – 4.0 m
- > circumferential length: 1.0 – 8.0 m
- > colour: yellow
- > according to EN 1492-2
- > GS-tested

Designation	Item number
Round sling 3t yellow 1.0 m circumference	610300100027
Round sling 3t yellow 2.0 m circumference	610300200027
Round sling 3t yellow 3.0 m circumference	610300300027
Round sling 3t yellow 4.0 m circumference	610300400027
Round sling 3t yellow 5.0 m circumference	610300500027
Round sling 3t yellow 6.0 m circumference	610300600027
Round sling 3t yellow 8.0 m circumference	610300800027



### Technical data

- > nominal load capacity: 4,000 kg
- > useful length: 1.0 – 4.0 m
- > circumferential length: 2.0 – 8.0 m
- > colour: grey
- > according to EN 1492-2
- > GS-tested

Designation	Item number
Round sling 4t grey 2.0 m circumference	610400200027
Round sling 4t grey 4.0 m circumference	610400400027
Round sling 4t grey 6.0 m circumference	610400600027
Round sling 4t grey 8.0 m circumference	610400800027



### Technical data

- > nominal load capacity: 6,000 kg
- > useful length: 2.0 – 4.0 m
- > circumferential length: 4.0 – 8.0 m
- > colour: brown
- > according to EN 1492-2
- > GS-tested

Designation	Item number
Round sling 6t brown 4.0 m circumference	610600400027
Round sling 6t brown 6.0 m circumference	610600600027
Round sling 6t brown 8.0 m circumference	610600800027

## Container seal cinch-up seal S 306

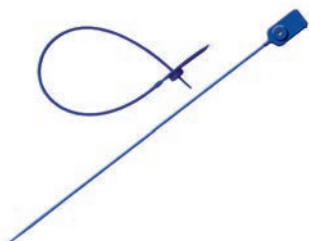

### Technical data

- > length: 375 mm
- > VPE: 1,000 pieces

Designation	Item number
Seal cinch-up seal S 306 length 375 mm	0340306

## Container seal mini cable breakaway

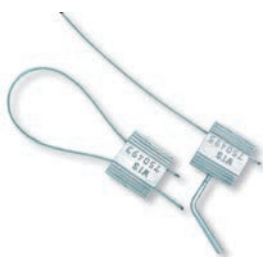

### Technical data

- > rope diameter: 2.5 mm
- > rope length: 180 mm

Designation	Item number
Seal mini cable breakaway 2.5 mm	0340104

## Container seal clicker



### Technical data

- > pin diameter: 9 mm
- > locking length: 45 mm

Designation	Item number
Seal clicker	0342211

127

## Anti-theft device "Tube Secure" door gear

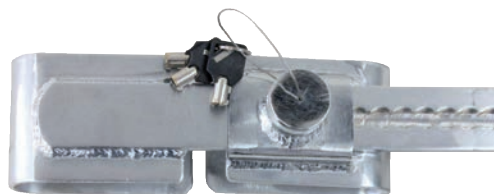

### Technical data

- > application range: 230 – 460 mm
- > up to tube diameter 33 mm
- > material: steel galvanised

Designation	Item number
Theft TubeSecure 230 – 460 mm	0342262

## One-way Key-Lock quick lashing system



The WISTRA one-way lashing system is an economical alternative to conventional lashing straps and consists of polypropylene fabric, buckle and a tensioning tool.

The KEY-LOCK system is mainly used to secure cargo in containers, aeroplanes, trucks and trains and on ships.

The reusable tensioners guarantee simple and quick lashing.



### Key-Lock webbing: Technical data

- > one-way lashing system
- > minimum breaking force: 2,000 daN
- > fabric width: 50 mm
- > presentation: 100 m roll

Designation	Item number
Key-Lock endless webbing tape 50 mm	410013850070



### Key-Lock buckle: Technical data

- > one-way lashing system
- > minimum breaking force: 2,000 daN
- > material: steel, vinyl-coated

Designation	Item number
Key-Lock buckles 2 t	411800000015

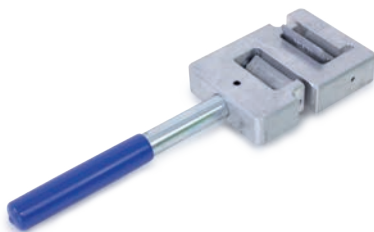

### Key-Lock manual tensioning device: Technical data

- > one-way lashing system
- > material: aluminium

Designation	Item number
Key-Lock manual clamping device aluminium	410000008120



## Reel tensioner



### Technical data

- > for straps up to 20 mm

Designation	Item number
Reel tensioner, Type AVT, 9-20	420000000615

## Buckles for straps



### Technical data

- > one-way lashing
- > VPE = 1,000 pieces

Designation	Item number
Buckles, 13 mm, Type B-4	420400000012
Buckles, 16 mm, Type B-5	420500000012
Buckles, 19 mm, Type B-6	420600000012

## Strapping for one-way lashings



### Technical data

- > width: 9 mm
- > tensile strength: 275 daN
- > presentation: 1,500 m roll

Designation	Item number
Packaging tape 9 mm type 30 S	420080300000

- > width: 13 mm
- > tensile strength: 390 daN
- > presentation: 1,100 m roll

Designation	Item number
Packing tape 13 mm	420080400000

- > width: 19 mm
- > tensile strength: 570 kN
- > presentation: 600 m roll

Designation	Item number
Packaging tape 19 mm type 60 S	420080600000

- > width: 16 mm
- > tensile strength: 470 daN
- > presentation: 850 m roll

Designation	Item number
Packaging tape 16 mm type 50 S	420080500000

---

# Interesting facts

---

## Terms

---

### Lashing devices

consist of the tensioning device (e.g. strap, chain, cord), the tensioning element (e.g. ratchet, winding mechanism, tension lock) and possibly the connecting element (end-fitting, hook)

### Lashing strap

is a lashing device consisting of the tensioning element or a lashing strap clamp and a lashing strap with or without connecting element.

### Strap

is a woven textile strap

### Tensioning element

is a mechanical device for introducing the tension force in a lashing device

### End-fitting

is a device for connecting the lashing strap or the tensioning element with the lashing point or the fixture point of the load

### Initial tension indicator

is a device indicating the initial tension in the lashing system

### Single-part lashing strap

is a lashing device consisting of a textile strap and a tensioning element (use of freely moveable end fittings is possible)

### Two-part lashing strap

is a lashing device consisting of two woven textile straps, one with a tensioning element, and both with one end-fitting

### Length $l_G$ – single-part lashing strap

measured from the end of the lashing strap up to the outer turn radius of its connection with the tensioning element

### Length $l_{GF}$ – short end

measured from the bearing point of the terminal bracket up to the outer turn radius of its connection with the tensioning element

### Length $l_{GL}$ – long end

measured from the end of the strap up to the bearing point of the terminal bracket piece

### Minimum breaking force $BF_{min}$

the breaking force for which a lashing strap is designed

### Lashing capacity LC

the highest force for use in straight traction for which a lashing strap is designed

### Functional factor

the relation between fixed minimum breaking force  $BF_{min}$  and lashing capacity LC

2 – for tensioning element and terminal bracket

3 – for strap

### Hand force HF

force on the grip of the tensioning element that produces traction in the lashing strap

### Standard hand force SHF

prescribed hand force of 500 N = 50 daN specified on the label

### Standard tension force STF

the remaining force after the grip of a ratchet has been let go at the prescribed hand force of 50 daN



the WIS label (example WTL 5550-006 SE 0.5 m)

## The WIS label

Reusable polyester lashing straps are furnished with one blue label for single-part lashing straps and with one label on each of the long ends and the short end for two-part lashing straps, which contain the following information:

### WIS label short end:

- > lashing capacity: LC value in daN
- > standard Hand Force: SHF 50 daN
- > standard Tension Force: STF value in daN
- > Warning: May not be used for lifting!
- > material specification: PES (for lashing straps with polyester webbing)
- > stretching of the lashing strap in % for LC value
- > name or symbol of the manufacturer
- > WIS tracking code
- > standard specification: EN 12195-2
- > year of manufacture

### WIS label long end:

- > lashing capacity: LC value in daN
- > Warning: May not be used for lifting!
- > material specification: PES (for lashing straps with polyester webbing)
- > stretching of the lashing strap in % for LC value
- > name or symbol of the manufacturer
- > WIS tracking code
- > standard specification: EN 12195-2
- > year of manufacture

## User information, additional label and User Manual

### Benutzerinformation

Es dürfen nur unbeschädigte Zurrgurte verwendet werden, deren Etikett lesbar ist. Unsachgemäße Ladungssicherung stellt eine Gefahr für das Leben von Personen, Tieren oder Gütern im Gefahrenbereich dar. Die praktischen Hinweise zur Benutzung und Pflege von Zurrgurten gemäß DIN EN 12195 - 2 Anhang B sind unbedingt einzuhalten.

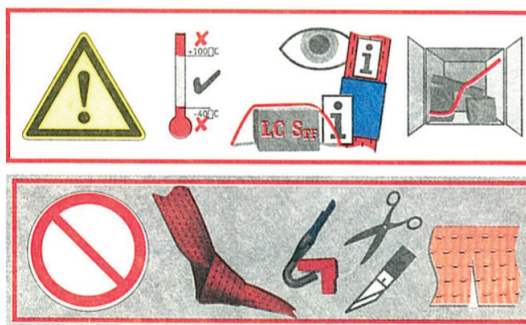

front page

back page

## Handling of straps

Only lashing straps which are furnished with legible labels may be used. The label must prove that the strap complies with DIN EN12195-2. No mechanical aids such as rods or levers which do not belong to the tensioning element may be used.

Lashing straps may not be knotted. Lashing straps must be protected against friction and abrasion as well as against sharp edges (see edge protectors).

## Handling of ratchets

The strap end of the long end is threaded in the winding shaft of the ratchet. By actuating the ratchet lever, the belt strap is wound up and thus tensioned owing to the drive shaft rotation. The lashing strap must be wound at least 1.5 times around the winding shaft to ensure the belt strap fits tightly. However, no more than three strap layers may be wound to prevent the lock slider from becoming stuck. To release the belt strap, the function slider must be pulled and the ratchet lever must be swivelled by approximately 180 degrees towards the limit stop. The initial tension is thereby released with a jolt. Therefore, the load must be checked beforehand for possible danger.

### Correct handling of ratchets



1. After pulling the function slider, lift up the ratchet lever and then insert the strap.

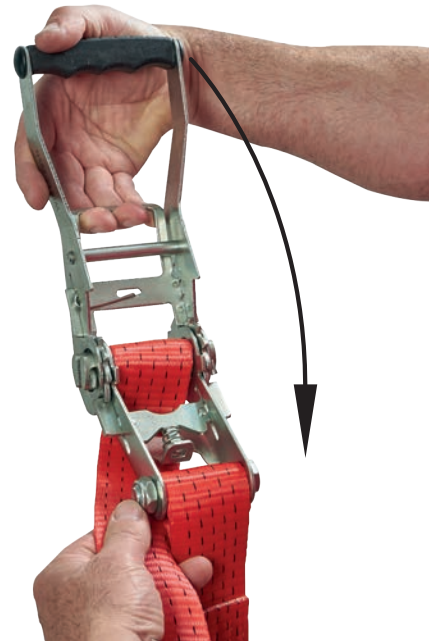

2. Pull the function slider and turn down the ratchet lever by approximately 180 degrees to release.

## Checking lashing straps and load securing devices.

In terms of the VDI 2700 Guideline, all devices used for load securing must in principle be subjected to an annual test by a qualified and authorised person. As a supplementary measure in terms of DIN EN 12195-2, testing of lashing straps made of chemical fibres is recommended before and after every use. WISTRA recommends this for all load securing devices.

**Discard criteria** means that the lashing strap must be withdrawn from use once specified wear characteristics become visible.

Some discard criteria for lashing straps:

- Data on the lashing strap labels is illegible.
- cuts in the material wider than 10% of total width - e.g. for lashing straps with a width of 50 mm = approx. 5 mm
- damage through heat or chemical influences
- increased corrosion, cracks and/or other deformations on the connecting elements (hooks) as well as the tensioning element (ratchet)

*Note: Particularly the winding elements must undergo close inspection.*

- The end-of-life of a lashing strap cannot be determined solely by its year of manufacture!

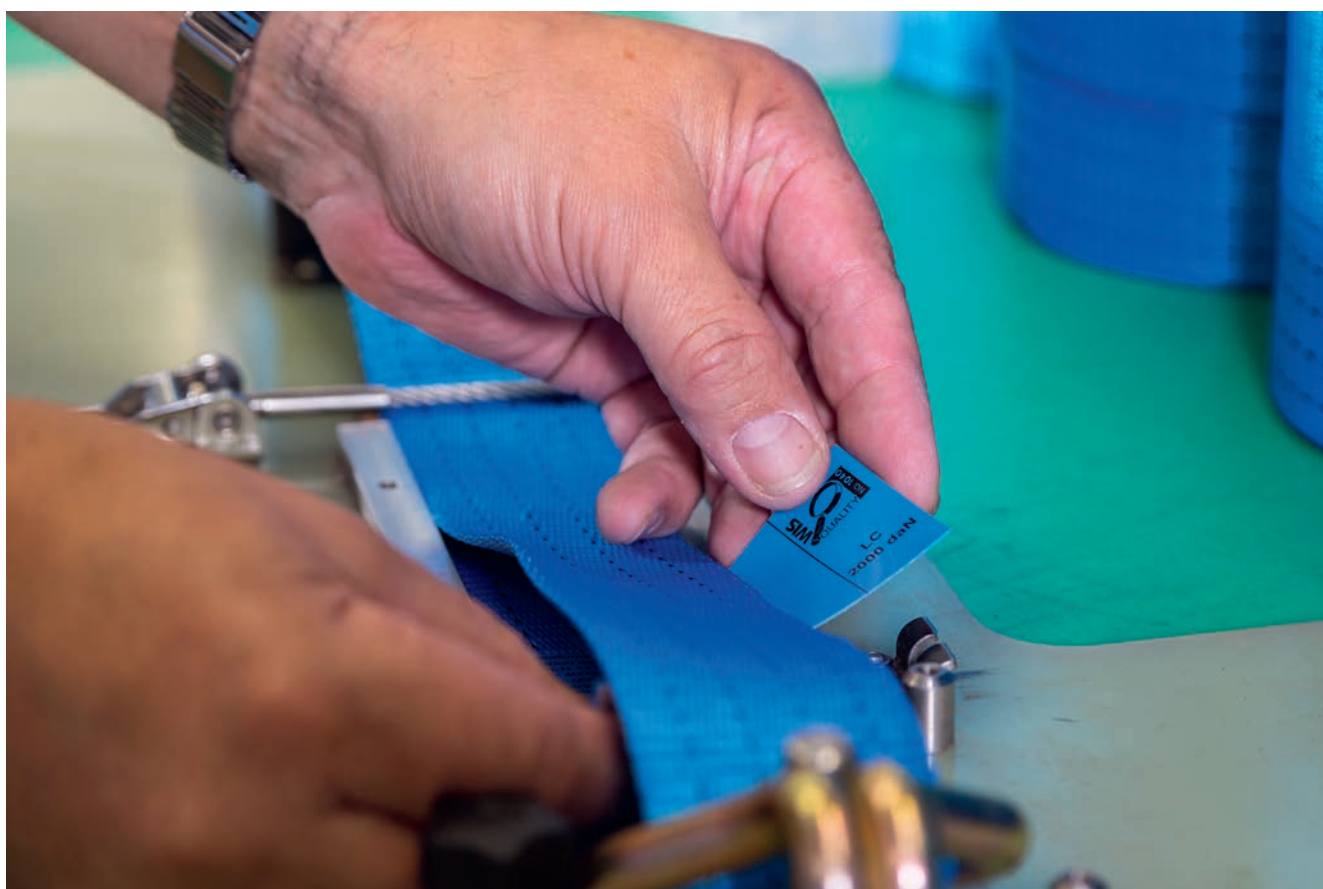



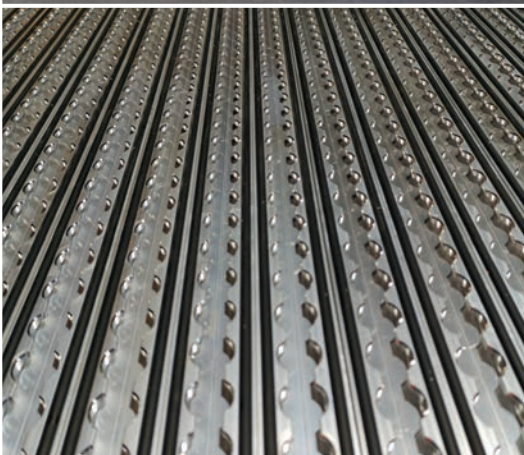
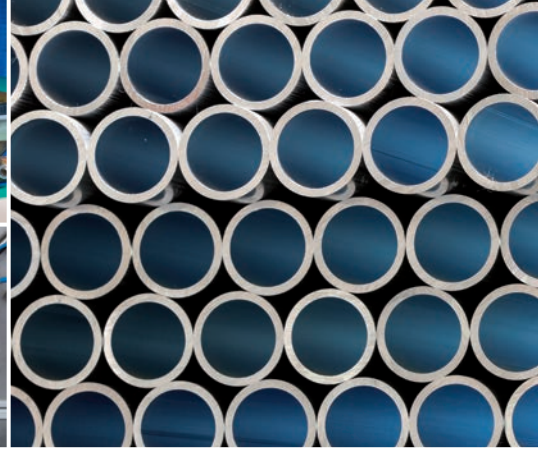



WORLD  CLASS

# CARGO

## SECUREMENT

KEEPING PEOPLE **SAFE**

FOR **50** YEARS



**WISTRA GmbH**  
Cargo Control  
An der Trave 11 • 23923 Selmsdorf  
Phone: +49 (0) 388 23 / 258-0  
Fax: +49 (0) 388 23 / 258-23  
E-mail: [info@wistra.eu](mailto:info@wistra.eu)

**UAB "Wistra Cargo Control"**  
Pramones 8  
LT-94102, Klaipeda  
Tel.: +370 61024943  
Tel.: +370 69565282  
E-mail: [masiule@wistra.eu](mailto:masiule@wistra.eu)

[www.wistra.eu](http://www.wistra.eu)



You can also visit us on Facebook:  
[www.facebook.com/wistra.eu](http://www.facebook.com/wistra.eu)